

SPECIFICATIONS FOR LCD MODULE

CUSTOMER	
CUSTOMER PART NO.	
AMPIRE PART NO.	AMA-156A02-DUC2510-G020
APPROVED BY	
DATE	

Preliminary Specification

Formal Specification

AMPIRE CO., LTD.

**4F., No.116, Sec. 1, Xintai 5th Rd., Xizhi Dist., New Taipei
City221, Taiwan (R.O.C.)**

新北市汐止區新台五路一段 116 號 4 樓(東方科學園區 A 棟)

TEL:886-2-26967269 , FAX:886-2-26967196 or 26967270

Approved by	Checked by	Organized by
Kokai	Simon	Tank

*This specification is subject to change without notice.

RECORD OF REVISION

Revision Date	Page	Contents	Editor
2018/10/03	--	New Release	Raymond
2018/10/30	3	Add information of weight	Raymond
2020/04/20	3~25	Change LCM solution and update specification	Tank

1.0 General Descriptions

1.1 Introduction

The LCM is a color active matrix TFT LCD module using amorphous silicon TFT's (Thin Film Transistors) as an active switching device. This module has a 15.6 inch diagonally measured active area with FHD resolutions (1920 horizontal by 1080 vertical pixel array). Each pixel is divided into RED, GREEN, BLUE dots which are arranged in vertical Stripe and this module can display **16M colors (6bit+FRC)**. The TFT-LCD panel used for this module is a low reflection and higher color type.

1.2 Features

- 3.3 V Logic Power
- LVDS (2ch) Interface for 1920 RGB x 1080 resolution
- **16M Colors(6bit+FRC)**
- On board LED Driving circuit
- Touch Panel

1.3 Product Summary

Items	Specifications	Unit
Screen Diagonal	15.6	Inch
Active Area	344.16 (H) x193.59 (V)	mm
Pixel Format	1920 (H) x RGB x 1080 (V)	-
Pixel Pitch	0.17925 (H) X 0.17925 (V)	mm
Pixel Arrangement	R.G.B. Vertical Stripe	-
Display Mode	Normally Black	-
White Luminance	382.5 (Typ.)	cd/m2
Contrast Ratio	800 : 1 (Typ.)	-
Input Voltage	3.3	V
Support Color	16M(6bit+FRC)	-

2.0 Absolute Maximum Ratings

TFT LCD Module

Item	Symbol	Values		Unit	Remark
		Min.	Max.		
Logic Input Voltage	V_{IN}	-0.3	4.0	V	
Power Supply Voltage	V_{DD}	-0.3	3.6	V	
Operation Temperature	T_{OP}	-30	85	°C	
Storage Temperature	T_{ST}	-40	90	°C	

Note(1) Permanent damage may occur to the LCD module if you operate beyond this specification. Functional operation should be restricted to the conditions which described under normal operating conditions.

Note(2) $T_a = 25 \pm 2^\circ\text{C}$

Note(3) Temperature and relative humidity range is shown in the figure below.

(a) 90 %RH Max. ($T_a \leq 40^\circ\text{C}$).

(b) Wet-bulb temperature should be 39°C Max. ($T_a > 40^\circ\text{C}$)

(c) No condensation.

Note(4) The absolute maximum rating values of this product are not allowed to be exceeded at any times.

The module should not be used over the absolute maximum rating value. It will cause permanently unrecoverable function fail in such a condition

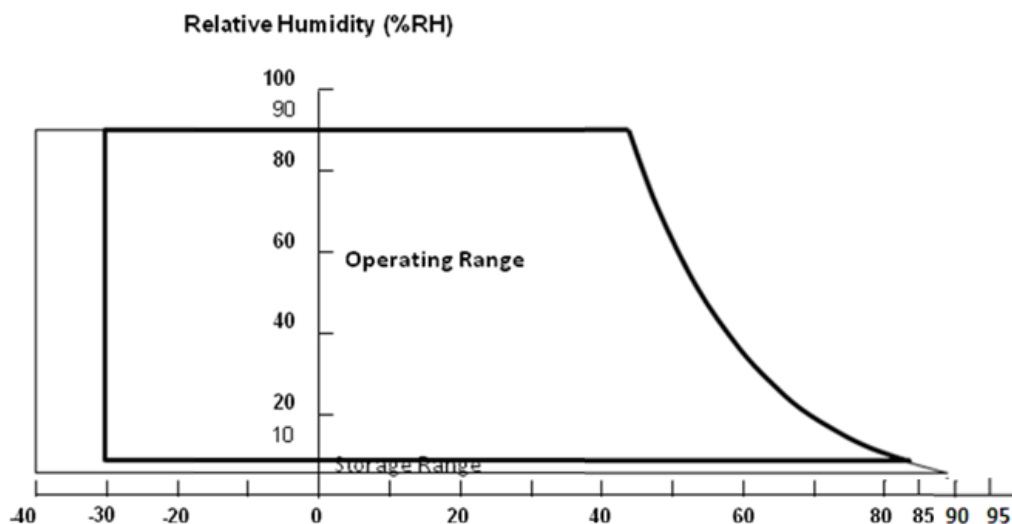

Backlight Converter

Item	Symbol	Value			Unit	Note
		Min.	Typ	Max.		
Converter Voltage	LED_V _{in}	0	12.0	18.0	V	(1), (2)
Enable Voltage	LED_EN	0	3.3 / 5	7	V	Duty=100%
Backlight Adjust	LED_PWM	0	3.3 / 5	7	V	(1), (2) Pulse Width ≤ 10msec. and Duty ≤ 10%

Note(1) Permanent damage to the device may occur if maximum values are exceeded. Function operation should be restricted to the conditions described under Normal Operating Conditions.

Note(2) Specified values are for input pin of LED light bar at Ta=25±2 °C (Refer to 4.3.3 and 4.3.4 for further information)

3.0 Electrical Specifications

3.1 LCD ELECTRONICS SPECIFICATION

Parameter	Symbol	Value			Unit	Note
		Min	Typ.	Max.		
Power Supply Voltage	V_{DD}	3.15	3.3	3.6	V	-
Ripple Voltage	VRP	-	-	150	mV	-
Rush Current	IRUSH	-	-	3	A	(2)
Power Supply Current	White	-	1.22	1.5	A	(3a)
	Black	-	0.51	0.7	A	(3b)
	Vertical Stripe	-	0.82	1	A	(3c)
Power Consumption	PLCD	-	4	5	Watt	(4)
LVDS differential input voltage	V_{id}	200		600	mV	(5)
LVDS common input voltage	V_{ic}	1.0	1.2	1.4	V	(6)
LVDS terminating resistor	R_t		100		ohm	

Note(1) The ambient temperature is $T_a = 25 \pm 2^\circ\text{C}$

Note(2) Measurement Conditions:

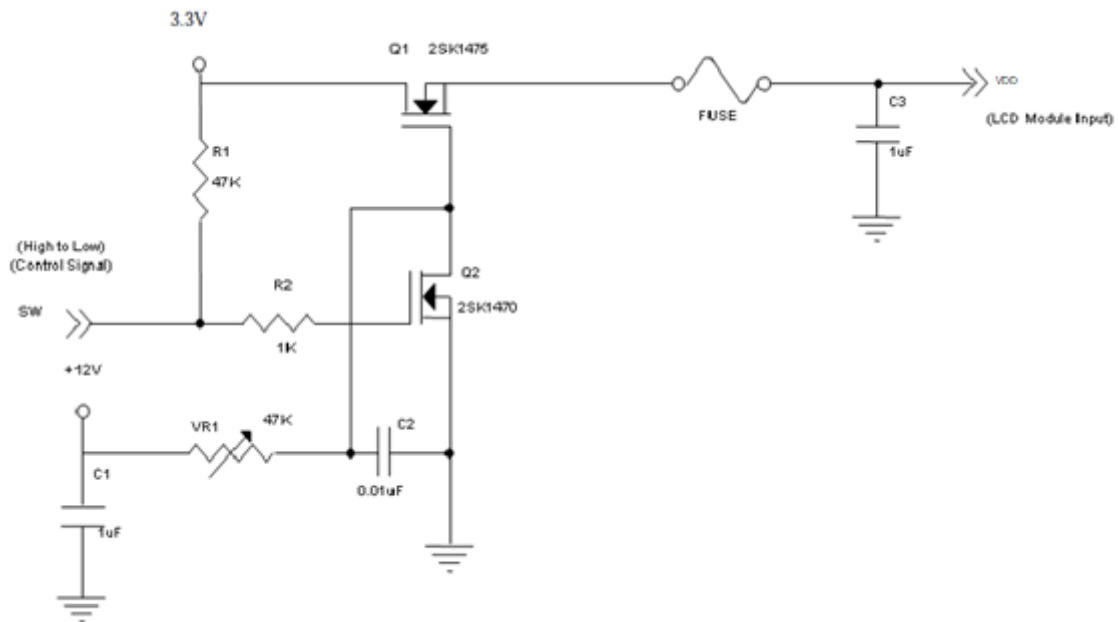

V_{DD} rising time is $470\mu\text{s}$

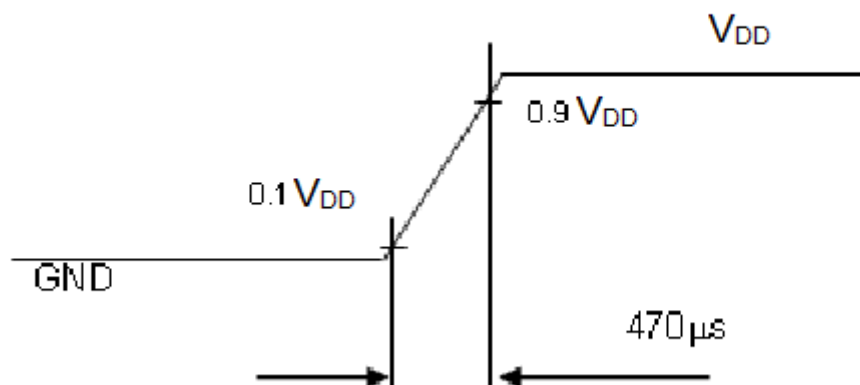

Note(1) The specified power supply current is under the conditions at $V_{DD} = 3.3V$, $T_a = 25 \pm 2^\circ C$, $F_r = 60Hz$, whereas a power dissipation check pattern below is displayed.

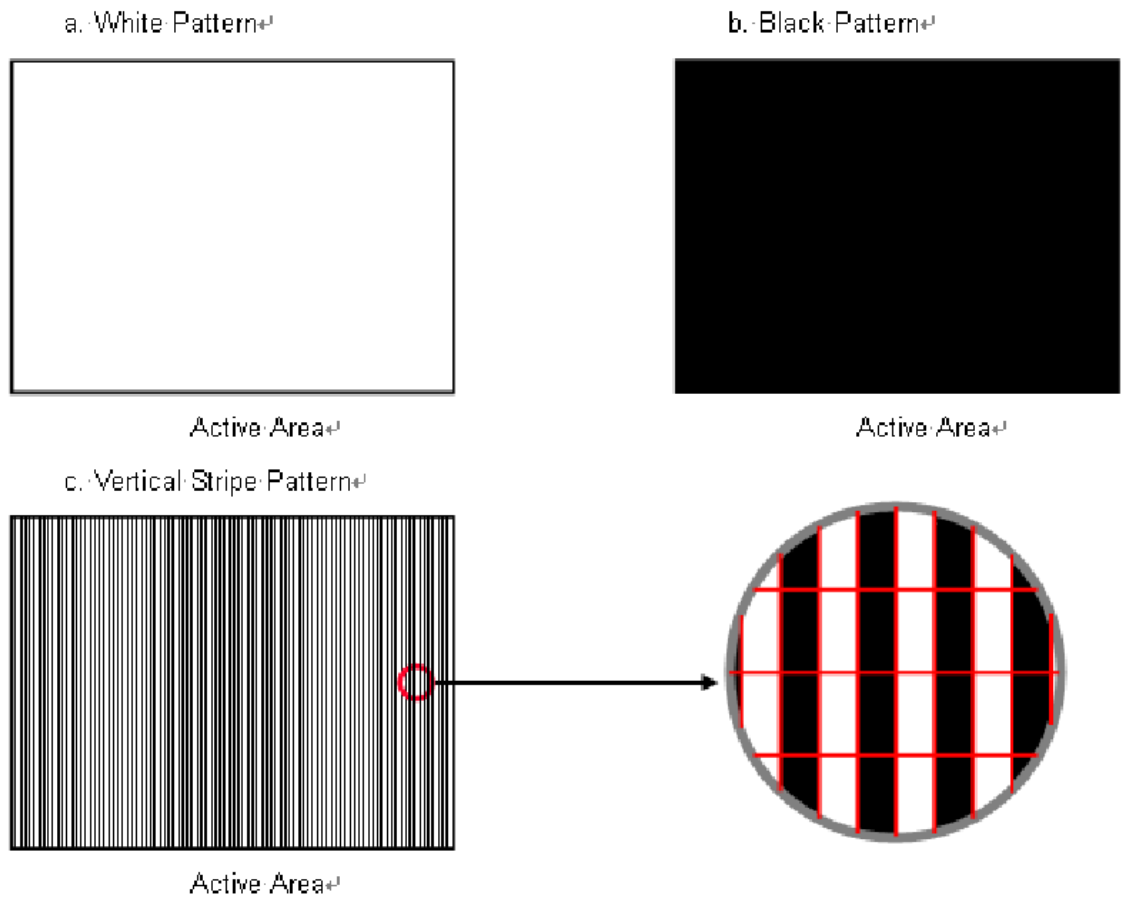

Note(2) The power consumption is specified at the pattern with the maximum current.

Note(3) VID waveform condition

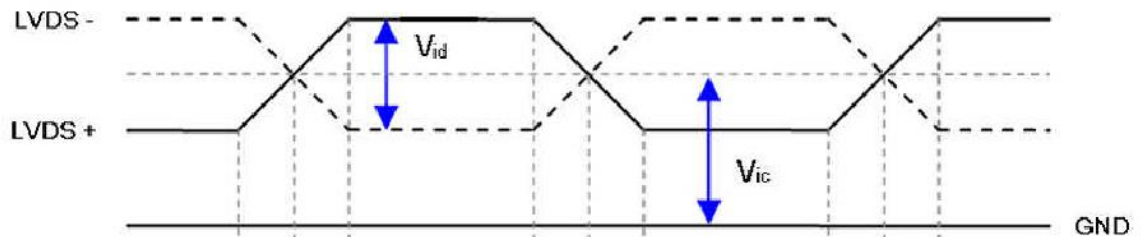

4.0 Interface Timings

4.1 Display Timing Specifications

The input signal timing specifications are shown as the following table and timing diagram.

*Note: The value for LVDS each channel

Signal	Item	Symbol	Min.	Typ.	Max.	Unit	Note
LVDS Clock	Frequency	Fc	60	70.93	75	MHz	-
	Period	Tc		14.1		ns	
	Input cycle to cycle jitter	T _{rd}	-0.02*Tc		0.02*Tc	ns	(3)
	Input clock to data skew	TLVCCS	-0.02*Tc		0.02*Tc	ns	(4)
	Spread spectrum modulation range	F _{clkin_mod}	FC*98%		FC*102%	MHz	(5)
	Spread spectrum modulation frequency	F _{SSM}			200	KHz	
Vertical Display Term	Frame Rate	Fr	50	60	60	Hz	Tv=Tvd+Tvb
	Total	Tv	1090	1110	1130	Th	-
	Active Display	Tvd	1080	1080	1080	Th	-
Horizontal Display Term	Blank	Tvb	Tv-Tvd	30	Tv-Tvd	Th	-
	Total	Th	1050	1065	1075	Tc	Th=Thd+Thb
	Active Display	Thd	960	960	960	Tc	-
	Blank	Thb	Th-Thd	105	Th-Thd	Tc	-

Note(1) Because this module is operated by DE only mode, Hsync and Vsync input signals are ignored.

Note(2) The Tv(Tvd+Tvb) must be integer, otherwise this module would operate abnormally.

Input Signal Timing Diagram

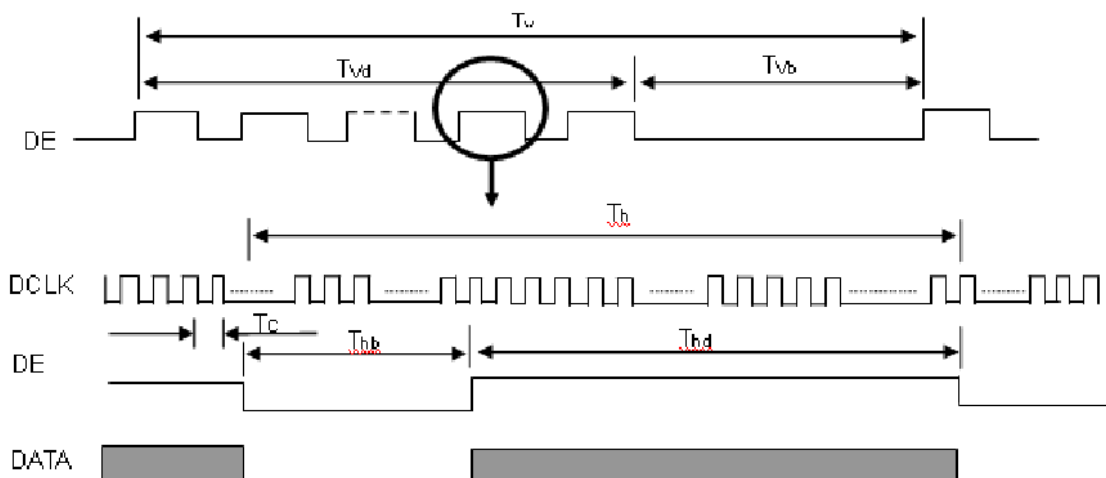

Note(3) The input clock cycle-to-cycle jitter is defined as below figures. $Trcl = |T_1 - T_2|$

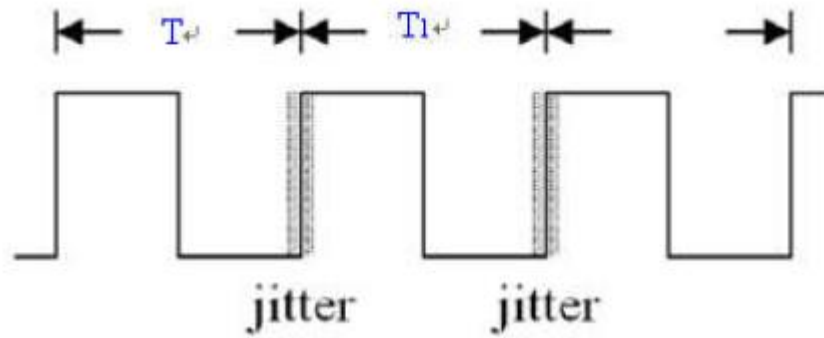

Note(4) Input Clock to data skew is defined as below figures.

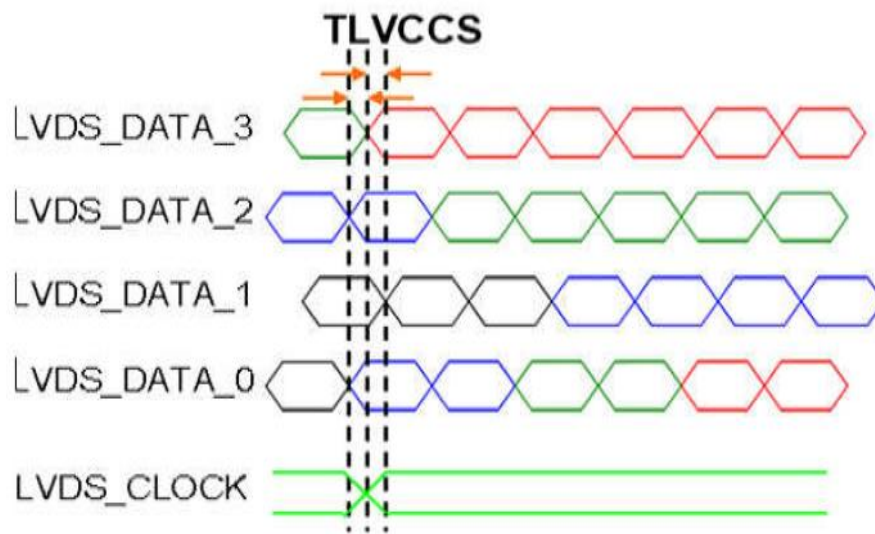

Note(5) The SSCG(Sprand spectrum clock generator) is defined as below figures.

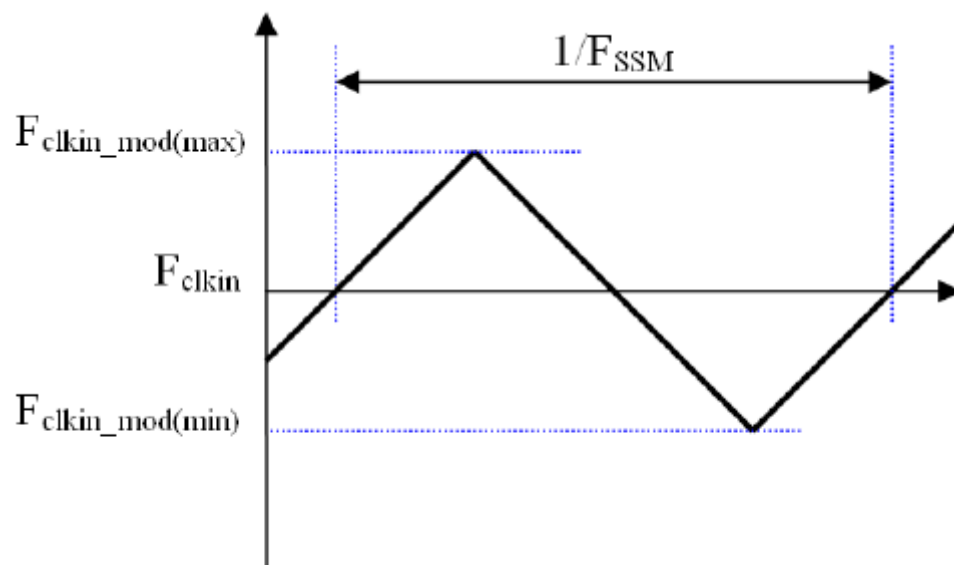

4.2 Power ON/OFF Sequence

The power sequence specifications are shown as the following table and diagram.

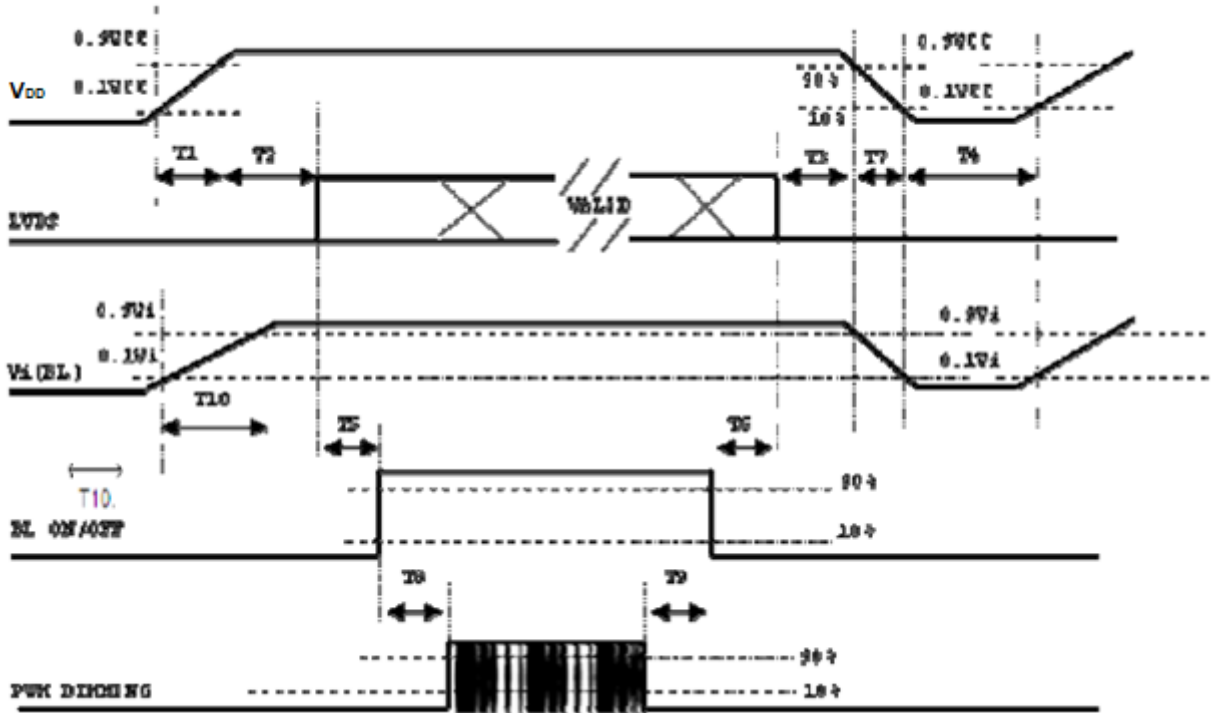

Timing Specifications:

Parameter	Value			Units
	Min	Typ	Max	
T1	0.5	-	10	ms
T2	0	-	50	ms
T3	0	-	50	ms
T4	500	-	-	ms
T5	450	-	-	ms
T6	200	-	-	ms
T7	10	-	100	ms
T8	10	-	-	ms
T9	10	-	-	ms
T10	20	-	50	ms

- Note (1) The supply voltage of the external system for the module input should be the same as the definition of V_{DD}.
- Note (2) When the backlight turns on before the LCD operation of the LCD turns off, the display may momentarily become abnormal screen.
- Note (3) In case of V_{DD} = off level, please keep the level of input signals on the low or keep a high impedance.
- Note (4) T4 should be measured after the module has been fully discharged between power off and on period.
- Note (5) Interface signal shall not be kept at high impedance when the power is on.

There might be slight electronic noise when LCD is turned off (even backlight unit is also off). To avoid this symptom, we suggest "V_{DD} falling timing" to follow "T7 spec".

4.3 LVDS Input Signal Specifications

4.3.1 LVDS Data Mapping Table

LVDS Channel O0	LVDS output	D7	D6	D4	D3	D2	D1	D0
	Data order	OG0	OR5	OR4	OR3	OR2	OR1	OR0
LVDS Channel O1	LVDS output	D18	D15	D14	D13	D12	D9	D8
	Data order	OB1	OB0	OG5	OG4	OG3	OG2	OG1
LVDS Channel O2	LVDS output	D26	D25	D24	D22	D21	D20	D19
	Data order	DE	NA	NA	OB5	OB4	OB3	OB2
LVDS Channel O3	LVDS output	D23	D17	D16	D11	D10	D5	D27
	Data order	NA	OB7	OB6	OG7	OG6	OR7	OR6
LVDS Channel E0	LVDS output	D7	D6	D4	D3	D2	D1	D0
	Data order	EG0	ER5	ER4	ER3	ER2	ER1	ER0
LVDS Channel E1	LVDS output	D18	D15	D14	D13	D12	D9	D8
	Data order	EB1	EB0	EG5	EG4	EG3	EG2	EG1
LVDS Channel E2	LVDS output	D26	D25	D24	D22	D21	D20	D19
	Data order	DE	NA	NA	EB5	EB4	EB3	EB2
LVDS Channel E3	LVDS output	D23	D17	D16	D11	D10	D5	D27
	Data order	NA	EB7	EB6	EG7	EG6	ER7	ER6

4.3.2 Color Data Input Assignment

The brightness of each primary color (red, green and blue) is based on the 8-bit gray scale data input for the color. The higher the binary the color. The table below provides the assignment of color versus data input.

Color		Data Signal																						
		Red								Green								Blue						
		R7	R6	R5	R4	R3	R2	R1	R0	G7	G6	G5	G4	G3	G2	G1	G0	B7	B6	B5	B4	B3	B2	B1
Basic Colors	Black	0	0	0	0	0	0	0	0	0	0	0	0	0	0	0	0	0	0	0	0	0	0	0
	Red	1	1	1	1	1	1	1	1	0	0	0	0	0	0	0	0	0	0	0	0	0	0	0
	Green	0	0	0	0	0	0	0	0	1	1	1	1	1	1	1	1	0	0	0	0	0	0	0
	Blue	0	0	0	0	0	0	0	0	0	0	0	0	0	0	0	0	1	1	1	1	1	1	1
	Cyan	0	0	0	0	0	0	0	0	1	1	1	1	1	1	1	1	1	1	1	1	1	1	1
	Magenta	1	1	1	1	1	1	1	1	0	0	0	0	0	0	0	0	1	1	1	1	1	1	1
	Yellow	1	1	1	1	1	1	1	1	1	1	1	1	1	1	1	1	0	0	0	0	0	0	0
	White	1	1	1	1	1	1	1	1	1	1	1	1	1	1	1	1	1	1	1	1	1	1	1
Gray Scale Of Red	Red(0) / Dark	0	0	0	0	0	0	0	0	0	0	0	0	0	0	0	0	0	0	0	0	0	0	
	Red(1)	0	0	0	0	0	0	0	1	0	0	0	0	0	0	0	0	0	0	0	0	0	0	
	Red(2)	0	0	0	0	0	0	1	0	0	0	0	0	0	0	0	0	0	0	0	0	0	0	
	
	
	
	Red(253)	1	1	1	1	1	1	0	1	0	0	0	0	0	0	0	0	0	0	0	0	0	0	
Red(254)	1	1	1	1	1	1	1	0	0	0	0	0	0	0	0	0	0	0	0	0	0	0		
Red(255)	1	1	1	1	1	1	1	1	0	0	0	0	0	0	0	0	0	0	0	0	0	0		
Gray Scale Of Green	Green(0)/Dark	0	0	0	0	0	0	0	0	0	0	0	0	0	0	0	0	0	0	0	0	0	0	
	Green(1)	0	0	0	0	0	0	0	0	0	0	0	0	0	0	1	0	0	0	0	0	0	0	
	Green(2)	0	0	0	0	0	0	0	0	0	0	0	0	0	1	0	0	0	0	0	0	0	0	
	
	
	
	Green(253)	0	0	0	0	0	0	0	1	1	1	1	1	1	0	1	0	0	0	0	0	0	0	
Green(254)	0	0	0	0	0	0	0	1	1	1	1	1	1	1	0	0	0	0	0	0	0	0		
Green(255)	0	0	0	0	0	0	0	1	1	1	1	1	1	1	1	0	0	0	0	0	0	0		
Gray Scale Of Blue	Blue(0) / Dark	0	0	0	0	0	0	0	0	0	0	0	0	0	0	0	0	0	0	0	0	0	0	
	Blue(1)	0	0	0	0	0	0	0	0	0	0	0	0	0	0	0	0	0	0	0	0	0	1	
	Blue(2)	0	0	0	0	0	0	0	0	0	0	0	0	0	0	0	0	0	0	0	0	0	1	
	
	
	
	Blue(253)	0	0	0	0	0	0	0	0	0	0	0	0	0	0	0	1	1	1	1	1	1	0	
Blue(254)	0	0	0	0	0	0	0	0	0	0	0	0	0	0	0	1	1	1	1	1	1	0		
Blue(255)	0	0	0	0	0	0	0	0	0	0	0	0	0	0	0	1	1	1	1	1	1	1		

Note (1) 0: Low Level Voltage, 1: High Level Voltage

5.0 Optical Specifications

5.1 Test Conditions

Item	Symbol	Value	Unit
Ambient Temperature	Ta	25±2	°C
Ambient Humidity	Ha	50±10	%RH
Supply Voltage	According to typical value in "ELECTRICAL CHARACTERISTICS"		
Input Signal			
LED Light Bar Input Current Per Input Pin			

5.2 Optical Specifications

The optical characteristics are measured under stable conditions as following notes. The relative measurement methods of optical characteristics are shown in 5.2 and all items are measured at the center point of screen except white variation. The following items should be measured under the test conditions described in 5.1 and stable environment shown in Note (5).

Item	Conditions		Min.	Typ.	Max.	Unit	Note
Viewing Angle (CR>10)	Horizontal	θ_{x-}	80	85	-	degree	Note (1)(5)
		θ_{x+}	80	85	-		
	Vertical	θ_{y-}	80	85	-		
		θ_{y+}	80	85	-		
Contrast Ratio	Center		600	800	-	-	Note (2)(5)
Response Time	Rising + Falling		-	25	35	ms	Note (3)
Color Chromaticity (CIE1931)	Red	x	Typ. -0.05	0.652	Typ. +0.05	-	Note (1)(5)
	Red	y		0.338		-	
	Green	x		0.333		-	
	Green	y		0.613		-	
	Blue	x		0.150		-	
	Blue	y		0.050		-	
	White	x		0.313		-	
	White	y		0.329		-	
White Luminance	Center		306	382.5	-	cd/m ²	Note (4)(5)
Luminance Uniformity	9Points		70	-	-	%	Note (5)(6)

Note(1) Definition of Viewing Angle (θ_x, θ_y):

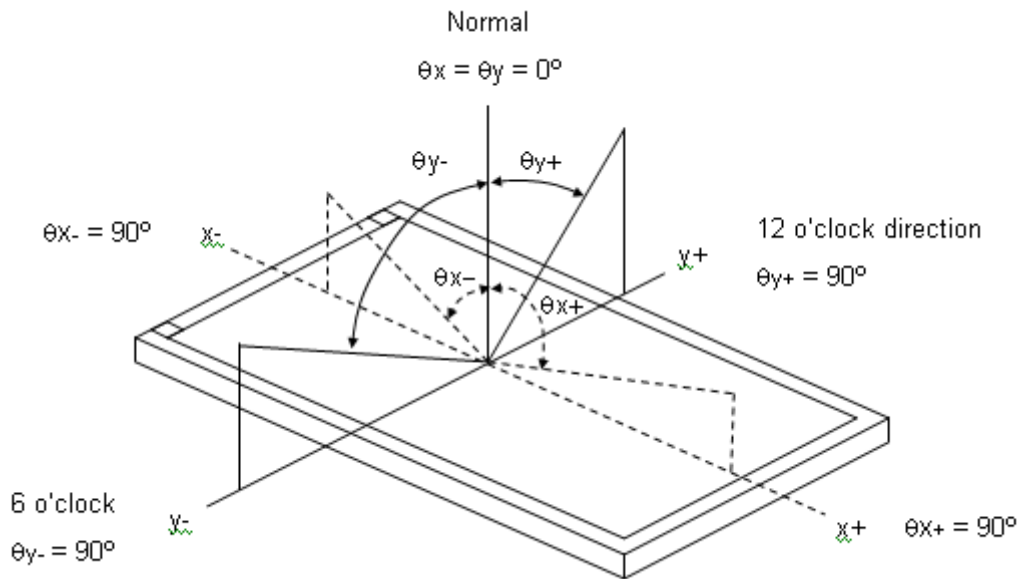

Note(2) Definition of Contrast Ratio (CR):

The contrast ratio can be calculated by the following expression.

$$\text{Contrast Ratio (CR)} = L_{255} / L_0$$

L255: Luminance of gray level 255

L 0: Luminance of gray level 0

$$\text{CR} = \text{CR} (5)$$

CR (X) is corresponding to the Contrast Ratio of the point X at Figure in Note (6).

Note(3) Definition of Response Time (T_R, T_F):

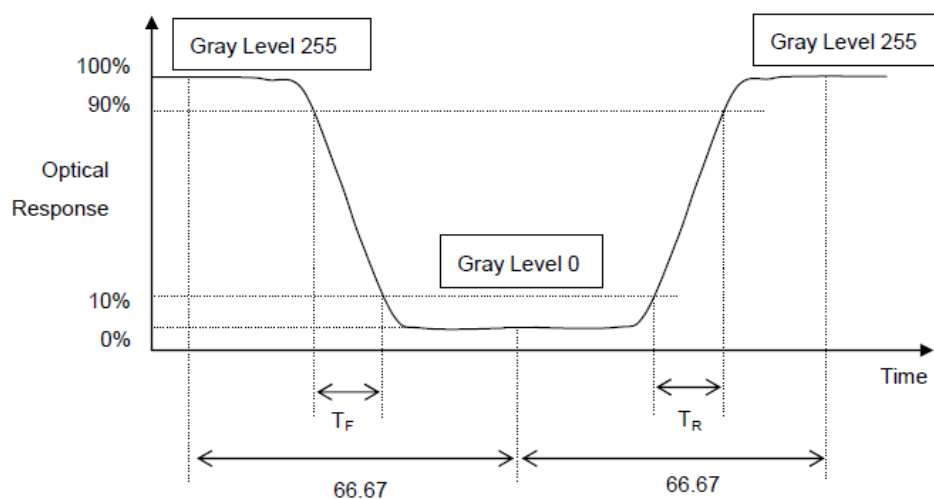

Note(4) Definition of Luminance of White (LC):

Measure the luminance of gray level 255 at center point

$LC = L(5)$

L(x) is corresponding to the luminance of the point X at Figure in Note (6).

Note(5) Measurement Setup:

The LCD module should be stabilized at given temperature for 30 minutes to avoid abrupt temperature change during measuring. In order to stabilize the luminance, the measurement should be executed after lighting Backlight for 30 minutes in a windless room.

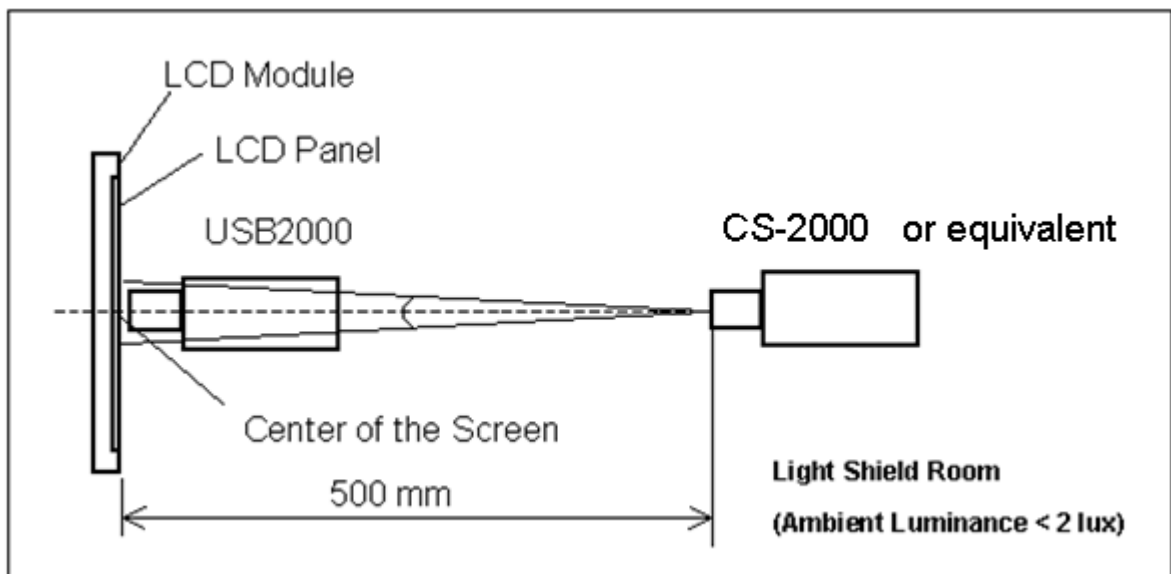

Note(6) Definition of White Variation (Uniformity):

Measure the luminance of gray level 255 at 9 points

Uniformity = (Minimum [L(1) ~ L(9)] / Maximum [L(1) ~ L(9)]) * 100%

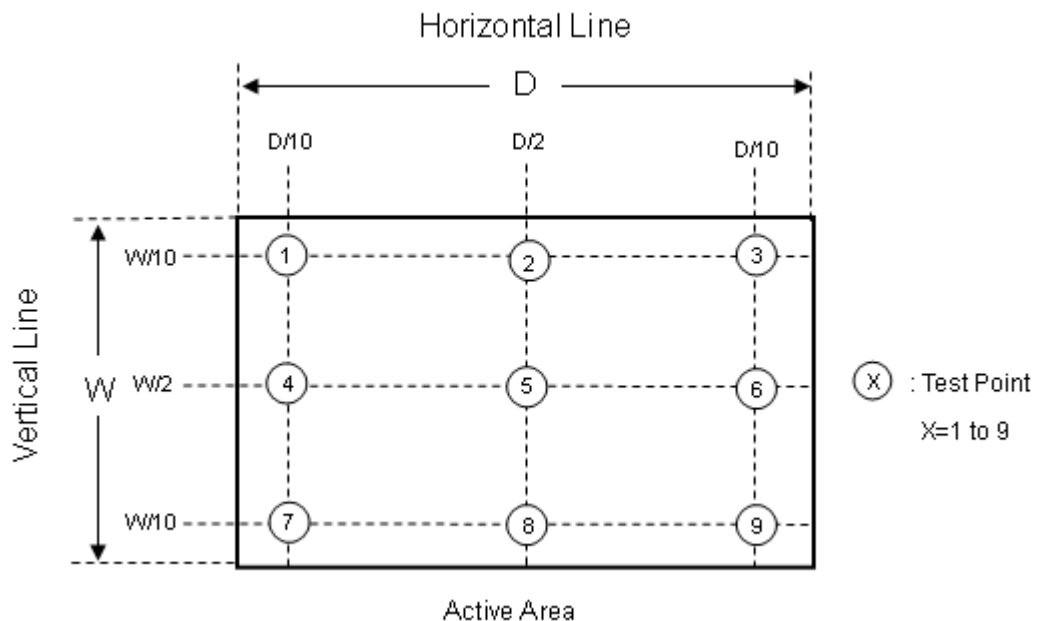

6.0 Interface Connections

Pin #	Signal Name	Description
1	GND	Ground
2	NC	Not Connect
3	VDD	Power Supply
4	VDD	Power Supply
5	GND	Ground
6	GND	Ground
7	NC	Not Connect
8	NC	Not Connect
9	GND	Ground
10	IN0-	-LVDS differential data input
11	IN0+	+LVDS differential data input
12	IN1-	-LVDS differential data input
13	IN1+	+LVDS differential data input
14	IN2-	-LVDS differential data input
15	IN2+	+LVDS differential data input
16	CLK-	-LVDS differential clock
17	CLK+	+LVDS differential clock
18	IN3-	-LVDS differential data input
19	IN3+	+LVDS differential data input
20	E_IN0-	-LVDS differential data input
21	E_IN0+	+LVDS differential data input
22	E_IN1-	-LVDS differential data input
23	E_IN1+	+LVDS differential data input
24	E_IN2-	-LVDS differential data input
25	E_IN2+	+LVDS differential data input
26	E_CLK-	-LVDS differential clock
27	E_CLK+	+LVDS differential clock
28	E_IN3-	-LVDS differential data input
29	E_IN3+	+LVDS differential data input
30	GND	Ground
31	GND	Ground
32	VLED	LED Power Supply
33	VLED	LED Power Supply
34	VLED	LED Power Supply

35	VLED	LED Power Supply
36	LED_EN	LED Enable Pin : High→Enable
37	LED_PWM	PWM Signal for LED Dimming Control
38	GND	Ground
39	GND	Ground
40	GND	Ground

7.0 LED Driving Conditions

Parameter		Symbol	Value			Unit	Note
			Min.	Typ.	Max.		
Converter Power Supply Voltage		V_{LED}	10.8	12.0	13.2	V	
Converter Power Supply Current		I_{LED}	800	1000	1200	mA	@ $V_{LED}=12V$ Duty=100%
Converter Input Rush Current		I_{rush}	--	--	3	A	@ V_{LED} rising = 1mS
Power Consumption		P_{LED}	--	12		W	@ $V_{LED}=12V$ Duty=100%
EN Control Level	Backlight on	LED_EN	2.0	5	5.5	V	
	Backlight off		0	0	0.15		
PWM Control Level	PWM High Level	LED_PWM	2.0	3.3	5.0	V	
	PWM Low Level		0	0	0.15		
PWM Control Duty Ratio			10	--	100	%	
PWM Control Frequency		f_{PWM}	190	200	20k	Hz	
LED Life Time		-	50,000			Hrs	(2)

Note(1) LED light bar input voltage and current are measured by utilizing a true RMS multi-meter as shown below:

Note(2) The lifetime of LED is estimated data and defined as the time when it continues to operate under the conditions at $T_a = 25 \pm 2^\circ\text{C}$ and Duty 100% until the brightness becomes $\leq 50\%$ of its original value. Operating LED under high temperature environment will reduce life time and lead to color shift.

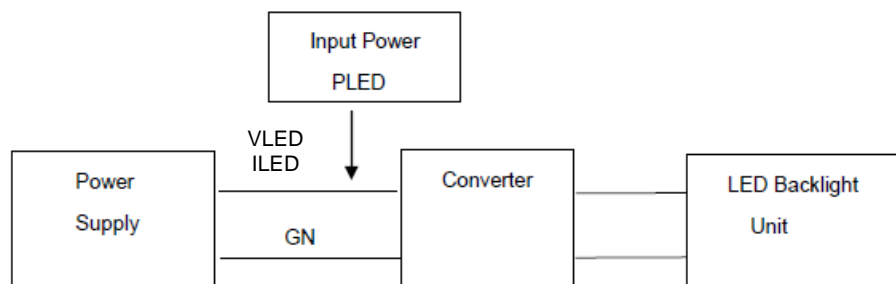

Note(3) Condition: $T_a=25^{\circ}\text{C}$, continuous lighting. Life time is estimated data.

Definitions of failure:

1. LCM brightness becomes half of the minimum value.
2. LED doesn't light normally.

When LCM is operated over 40°C ambient temperature, the I_{LED} should follow :

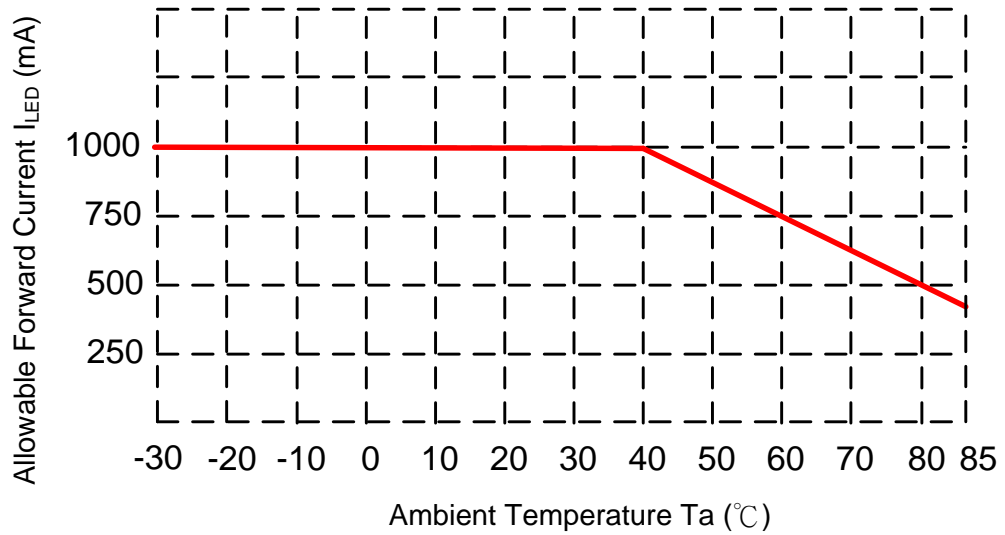

8.0 Touch panel electrical specification

8.1 Electrical characteristics

ITEM	SPECIFICATION
Type	Projective Capacitive Touch Panel
Activation	Two-fingers or Single-finger
X/Y Position Reporting	Absolute Position
Touch Force	No contact pressure required
Calibration	No need for calibration
Report Rate	Approx. 200 points/sec
Control IC	ILI2510

ITEM	Symbol	MIN	TYP	MAX	UNIT
Touch panel power supply	VCC_5V	4.5	5	5.5	V
Touch panel power supply current at Normal operation mode	I _{VCC_5V}	--	93.28	139.92	mA

8.2 Interface

Pin No.	Symbol	Function
1	VCC_5V	USB POWER 5V
2	D+	USB Data+
3	D-	USB Data-
4	NC	No connection
5	NC	No connection
6	GND	GND

9.0 Reliability Test

The reliability test items and its conditions are shown below.

Test Item	Test Conditions	Note
High Temperature Operation	85°C , t=240 hrs	(1)(2) (4)(5)
Low Temperature Operation	-30°C , t=240 hrs	
High Temperature Storage	90°C , t=240 hrs	
Low Temperature Storage	-40°C , t=240 hrs	
Storage at High Temperature and Humidity	60°C, 90% RH , 240 hrs	(1)(2) (4)(6)
Thermal Shock Storage Test	-20°C (30min) ~ 60°C (30min) , 100 cycles	(2)(3)
Vibration Test (Packing)	Sweep frequency : 10~55~10 Hz/1min Amplitude : 0.75mm Test direction : X.Y.Z/3 axes Duration : 30 min/each axis	(2)(3)

Note(1) There should be no condensation on the surface of panel during test.

Note(2) Temperature of panel display surface area should be 98 °C Max.

Note(3) At testing Vibration and Shock, the fixture in holding the module has to be hard and rigid enough so that the module would not be twisted or bent by the fixture.

Note(4) In the standard conditions, there is no function failure issue occurred. All the cosmetic specification is judged before reliability test.

Note(5) Before cosmetic and function test, the product must have enough recovery time, at least 2 hours at room temperature.

Note(6) Before cosmetic and function test, the product must have enough recovery time, at least 24 hours at room temperature.

Note(7) Condensation of water is not permitted on the module.

Note(8) The module should be inspected after 1 hour storage in normal conditions (15-35°C, 45-65%RH).

Note(9) The module shouldn't be tested more than one condition, and all the test conditions are independent.

Note(10) All the reliability tests should be done without protective film on the module.

10.0 General Precaution

10.1 Use Restriction

- (1) This product is not authorized for use in life supporting systems, aircraft navigation control systems, military systems and any other application where performance failure could be life-threatening or otherwise catastrophic.

10.2 Disassembling or Modification

- (1) Do not disassemble or modify the module. It may damage sensitive parts inside LCD module, and may cause scratches or dust on the display. AMPIRE does not warrant the module, if customers disassemble or modify the module.

10.3 Breakage of LCD Panel

- (1) If LCD panel is broken and liquid crystal spills out, do not ingest or inhale liquid crystal, and do not contact liquid crystal with skin.
- (2) If liquid crystal contacts mouth or eyes, rinse out with water immediately.
- (3) If liquid crystal contacts skin or cloths, wash it off immediately with alcohol and rinse thoroughly with water.
- (4) Handle carefully with chips of glass that may cause injury, when the glass is broken.

10.4 Electric Shock

- (1) Disconnect power supply before handling LCD module.
- (2) Do not pull or fold the LED cable.
- (3) Do not touch the parts inside LCD modules and the fluorescent LED's connector or cables in order to prevent electric shock.

10.5 Absolute Maximum Ratings and Power Protection Circuit

- (1) Do not exceed the absolute maximum rating values, such as the supply voltage variation, input voltage variation, variation in parts' parameters, environmental temperature, etc., otherwise LCD module may be damaged.
- (2) Please do not leave LCD module in the environment of high humidity and high temperature for a long time.
- (3) It's recommended to employ protection circuit for power supply.

10.6 Operation

- (1) Do not touch, push or rub the polarizer with anything harder than HB pencil lead.
- (2) Use fingerstalls of soft gloves in order to keep clean display quality, when persons handle the LCD module for incoming inspection or assembly.
- (3) When the surface is dusty, please wipe gently with absorbent cotton or other soft material.
- (4) Wipe off saliva or water drops as soon as possible. If saliva or water drops contact with polarizer for a long time, they may cause deformation or color fading.
- (5) When cleaning the adhesives, please use absorbent cotton wetted with a little petroleum benzene or other adequate solvent.

10.7 Mechanism

- (1) Please mount LCD module by using mounting holes arranged in four corners tightly.
- (2) The square adhesive tape which is between the touch panel and display can't provide well supporting in the long term and high ambient temperature condition. Whether upright or horizontal position the support holder which is in the back side of the display is needed. Do not let the display floating.

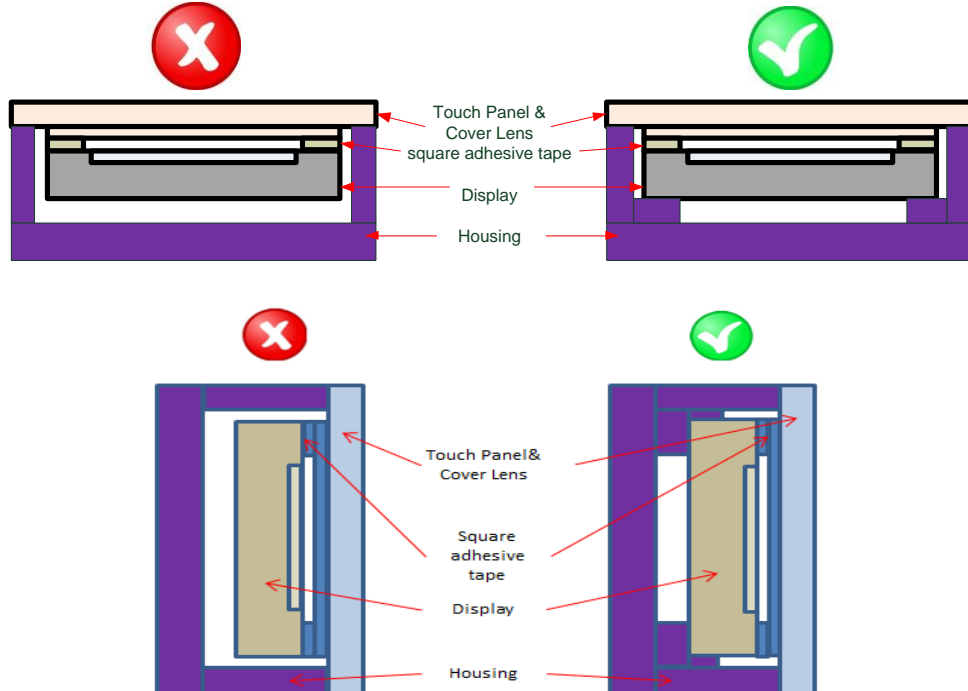

- (3) TP needs to work in environment with stable stray capacitance. In order to minimize the variation in stray capacitance, all conductive mechanical parts must not be floating. Intermittent floating any conductive part around the touch sensor may cause significant stray capacitance change and abnormal touch function. It is recommended to keep all conductive parts having same electrical potential as the GND of the touch controller module.

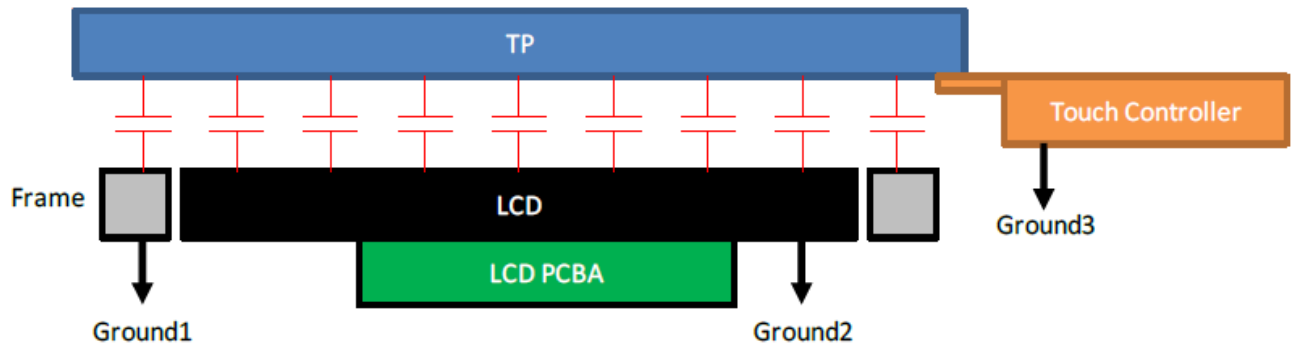

GND1, GND2 and GND3 should be connected together to have the same ground

10.8 Static Electricity

- (1) Protection film must remove very slowly from the surface of LCD module to prevent from electrostatic occurrence.
- (2) Because LCD modules use CMOS-IC on circuit board and TFT-LCD panel, it is very weak to electrostatic discharge. Please be careful with electrostatic discharge. Persons who handle the module should be grounded through adequate methods.

10.9 Strong Light Exposure

- (1) The module shall not be exposed under strong light such as direct sunlight. Otherwise, display characteristics may be changed.

10.10 Disposal

- (1) When disposing LCD module, obey the local environmental regulations.

10.11 Others

- (1) Do not keep the LCD at the same display pattern continually. The residual image will happen and it will damage the LCD. Please use screen saver.

11. Outline Dimension

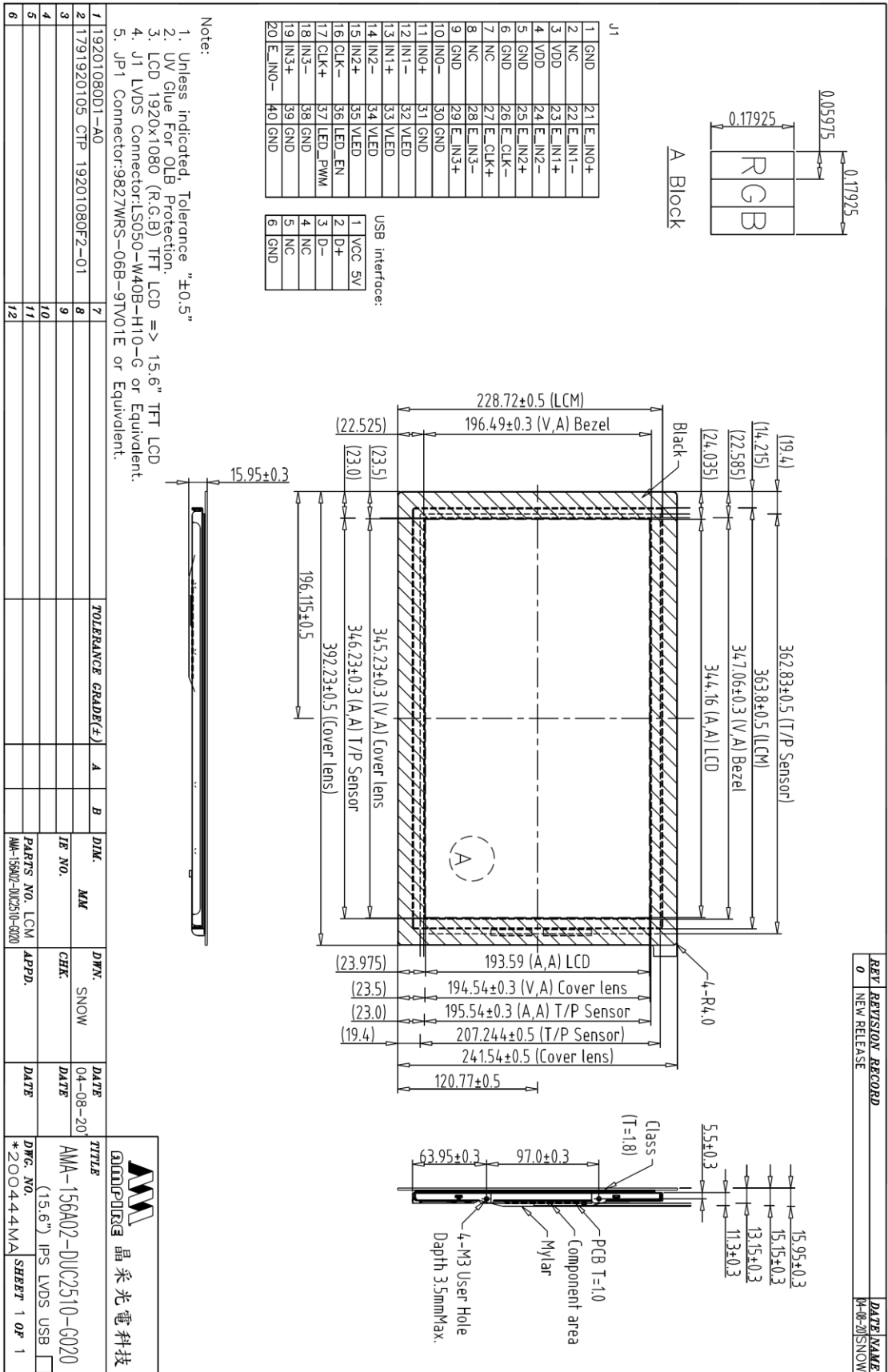

REV	REVISION RECORD	DATE NAME
0	NEW RELEASE	M-00-20/SNOW

USB interface:

1	VCC 5V
2	D+
3	D-
4	NC
5	NC
6	GND

1	GND	21	E_INO+
2	NC	22	E_IN1-
3	VDD	23	E_IN1+
4	VDD	24	E_IN2-
5	GND	25	E_IN2+
6	GND	26	E_CLK-
7	NC	27	E_CLK+
8	NC	28	E_IN3-
9	GND	29	E_IN3+
10	INO-	30	GND
11	INO+	31	GND
12	IN1-	32	VLED
13	IN1+	33	VLED
14	IN2-	34	VLED
15	IN2+	35	VLED
16	CLK-	36	LED_EN
17	CLK+	37	LED_PWM
18	IN3-	38	GND
19	IN3+	39	GND
20	E_INO-	40	GND

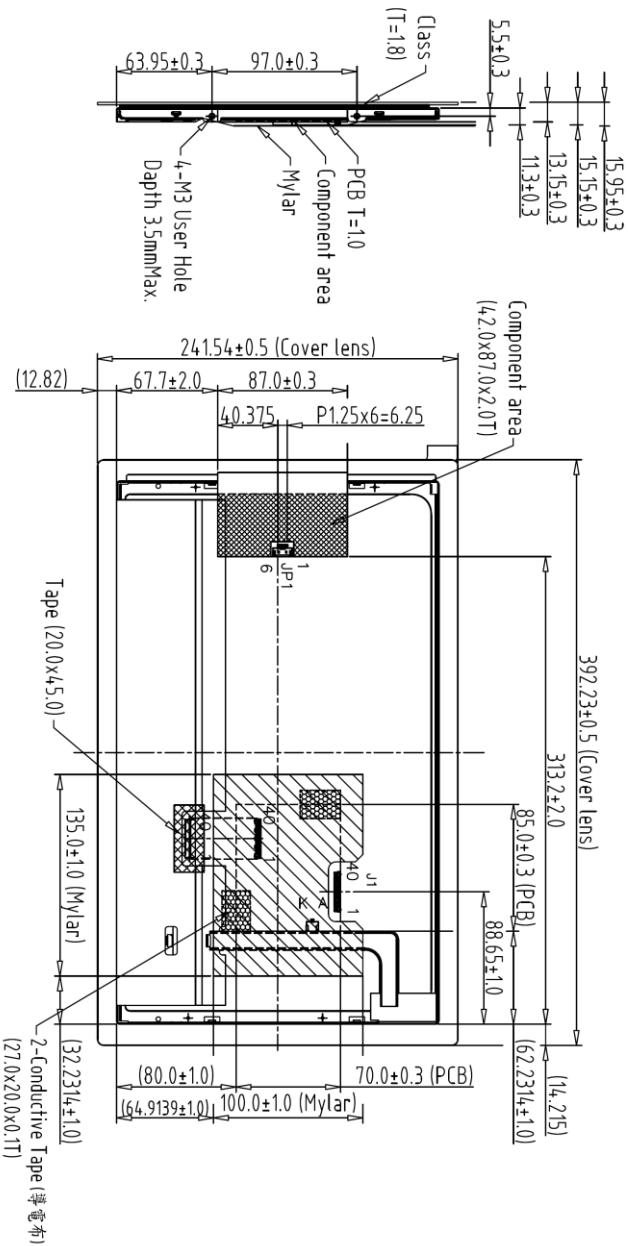

Note:

1. Unless indicated, Tolerance "±0.5"
2. UV Glue For OLB Protection.
3. LCD 1920x1080 (R:G:B) TFT LCD => 15.6" TFT LCD
4. J1 LVDS Connector:LS050-W40B-H10-G or Equivalent.
5. JP1 Connector:9827WRS-06B-9TV01E or Equivalent.

Back view

1	19201080D1-A0	7	TOLERANCE GRADE(±)		A	B	DIK.	MM	DNV.	SNOW	DATE	TTTE
2	1791920105 CTP 19201080F2-01	8									04-08-20	AMA-156A02-DUC2510-G020
3		9									DATE	(15.6") IPS LVDS USB
4		10									DATE	
5		11									DATE	
6		12									DATE	

PARTS NO. LCM-1 APPD.

AMA-156A02-DUC2510-G020

DMG. NO. *200445MA SHEET 1 OF 1