

- Tentative Specification
- Preliminary Specification
- Approval Specification

**MODEL NO.: G156HCE**  
**SUFFIX: LN2**

<b>Customer: AVNET</b>	
<b>APPROVED BY</b>	<b>SIGNATURE</b>
<b>Name / Title</b> _____	_____
Note	
_____	
Please return 1 copy for your confirmation with your signature and comments.	

Approved By	Checked By	Prepared By
林秋森	吳承旻	陳建紅

**CONTENTS**

<b>1. GENERAL DESCRIPTION .....</b>	<b>5</b>
1.1 OVERVIEW .....	5
1.2 FEATURE .....	5
1.3 APPLICATION .....	5
1.4 GENERAL SPECIFICATIONS .....	5
1.5 MECHANICAL SPECIFICATIONS .....	6
<b>2. ABSOLUTE MAXIMUM RATINGS .....</b>	<b>7</b>
2.1 ABSOLUTE RATINGS OF ENVIRONMENT .....	7
2.2 ELECTRICAL ABSOLUTE RATINGS .....	8
2.2.1 TFT LCD MODULE .....	8
2.2.2 BACKLIGHT UNIT .....	8
<b>3. ELECTRICAL CHARACTERISTICS .....</b>	<b>9</b>
3.1 TFT LCD MODULE .....	9
3.2 Vcc Power Dip Condition .....	10
3.3 BACKLIGHT UNIT .....	11
<b>4. BLOCK DIAGRAM .....</b>	<b>12</b>
4.1 TFT LCD MODULE .....	12
<b>5. INPUT TERMINAL PIN ASSIGNMENT .....</b>	<b>13</b>
5.1 TFT LCD MODULE .....	13
5.2 COLOR DATA INPUT ASSIGNMENT .....	15
<b>6. INTERFACE TIMING .....</b>	<b>16</b>
6.1 INPUT SIGNAL TIMING SPECIFICATIONS .....	16
6.2 POWER ON/OFF SEQUENCE .....	18
<b>7. OPTICAL CHARACTERISTICS .....</b>	<b>20</b>
7.1 TEST CONDITIONS .....	20
7.2 OPTICAL SPECIFICATIONS .....	20
<b>8. RELIABILITY TEST CRITERIA .....</b>	<b>24</b>
<b>9. PACKAGING .....</b>	<b>25</b>
9.1 PACKING SPECIFICATIONS .....	25
9.2 PACKING METHOD .....	25
9.3 UN-PACKING METHOD .....	26
<b>10. DEFINITION OF LABELS .....</b>	<b>27</b>
10.1 INX MODULE LABEL .....	27
<b>11. PRECAUTIONS .....</b>	<b>28</b>
11.1 ASSEMBLY AND HANDLING PRECAUTIONS .....	28
11.2 STORAGE PRECAUTIONS .....	28
11.3 OTHER PRECAUTIONS .....	29

**12. MECHANICAL CHARACTERISTICS ..... 30**  
**Appendix. SYSTEM COVER DESIGN NOTICE ..... 32**

## REVISION HISTORY

Version	Date	Page	Description
Ver 0.0	18 Dec 2024	All	Tentative Specification was first issued

## 1. GENERAL DESCRIPTION

### 1.1 OVERVIEW

G156HCE-LN2 is a 15.6" TFT Liquid Crystal Display IA module with LED Backlight units and 40 pins 2ch-LVDS interface. This module supports 1920 x 1080 FHD mode and can display 16.7M colors.

The PSWG is to establish a set of displays with standard mechanical dimensions and select electrical interface requirements for an industry standard 15.6" FHD LCD panel and the LED driving device for Backlight is built in PCBA.

### 1.2 FEATURE

- FHD (1920 x 1080 pixels) resolution
- DE (Data Enable) only mode
- 2ch-LVDS Interface
- PSWG (Panel Standardization Working Group)
- RoHS compliance

### 1.3 APPLICATION

- TFT LCD Monitor
- Factory Application
- Amusement

### 1.4 GENERAL SPECIFICATIONS

Item	Specification	Unit	Note
Active Area	344.16 (H) x 193.59(V) (15.6" diagonal)	mm	(1)
Driver Element	a-Si TFT active matrix	-	-
Pixel Number	1920 x R.G.B x 1080	pixel	-
Pixel Pitch	0.17925(H) x 0.17925 (W)	mm	-
Pixel Arrangement	RGB vertical Stripe	-	-
Display Colors	16.7M	color	-
Display Mode	Normally Black	-	-
Surface Treatment	Hard Coating (3H), Anti-Glare	-	-
Module Power Consumption	(Total 12.8W(Typ) @ Cell 3.2W(Typ),9.6W(Typ)	W	Typ.

**1.5 MECHANICAL SPECIFICATIONS**

Item		Min.	Typ.	Max.	Unit	Note
Module Size	Horizontal(H)	363.3	363.8	364.3	mm	(1)
	Vertical(V)	215.4	215.9	216.4	mm	
	Depth(D)	8.8	9.3	9.8	mm	
Bezel Area	Horizontal	346.76	347.06	347.36	mm	-
	Vertical	196.19	196.49	196.79	mm	
Active Area	Horizontal	-	344.16	-	mm	
	Vertical	-	193.59	-	mm	
Weight		-	1055	1097	g	

Note (1) Please refer to the attached drawings for more information of front and back outline dimensions.

**2. ABSOLUTE MAXIMUM RATINGS**

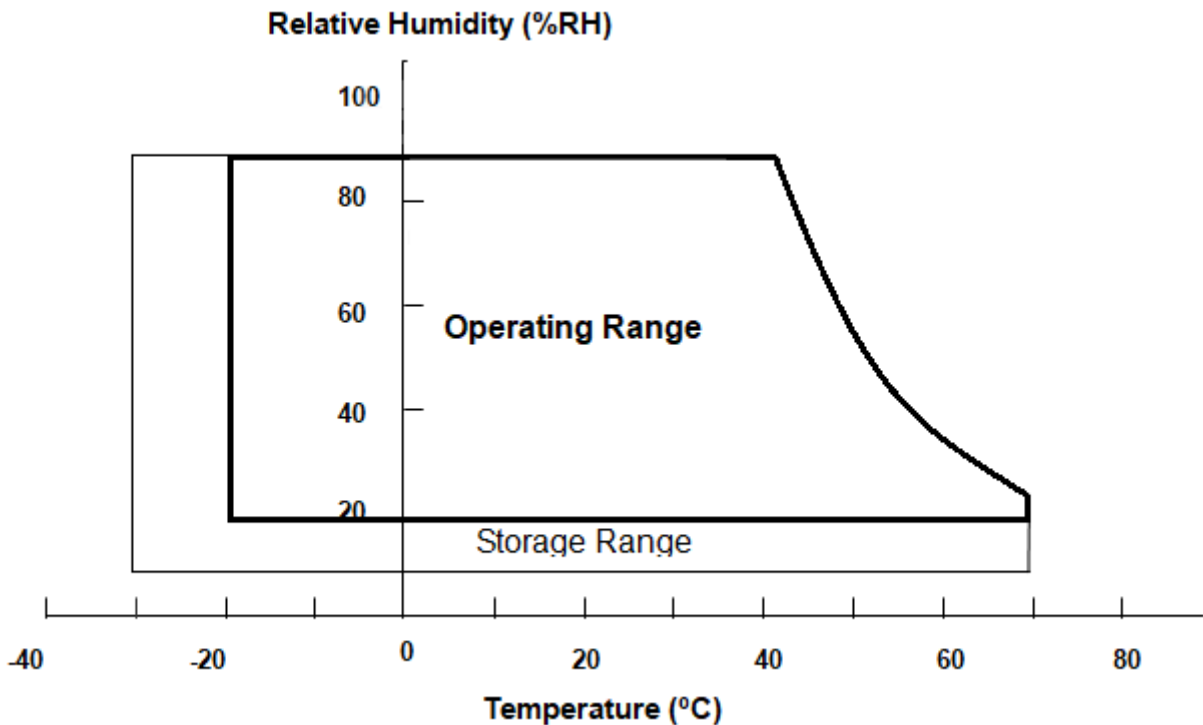
**2.1 ABSOLUTE RATINGS OF ENVIRONMENT**

Item	Symbol	Value		Unit	Note
		Min.	Max.		
Operating Ambient Temperature	T <sub>OP</sub>	-20	+70	°C	(1)(2)
Storage Temperature	T <sub>ST</sub>	-30	+70	°C	

Note (1)

- (a) 90 %RH Max.
- (b) Wet-bulb temperature should be 39 °C Max.
- (c) No condensation.

Note (2) Any condition of ambient operating temperature ,the surface of active area should be keeping not higher than 70°C. ( Panel sureface temperature )



## 2.2 ELECTRICAL ABSOLUTE RATINGS

### 2.2.1 TFT LCD MODULE

Item	Symbol	Value		Unit	Note
		Min.	Max.		
Power Supply Voltage	VCC	-0.3	5.5	V	(1)
Logic Input Voltage	V <sub>IN</sub>	-0.3	4.0	V	

### 2.2.2 BACKLIGHT UNIT

Item	Symbol	Value		Unit	Note
		Min.	Max.		
Converter Voltage	V <sub>i</sub>	-0.3	18	V	(1) , (2)
Enable Voltage	EN	-0.3	5.5	V	
Backlight Adjust	Dimming	-0.3	5.5	V	

Note (1) Permanent damage to the device may occur if maximum values are exceeded. Function operation should be restricted to the conditions described under Normal Operating Conditions.

Note (2) Specified values are for LED (Refer to 3.2 for further information).



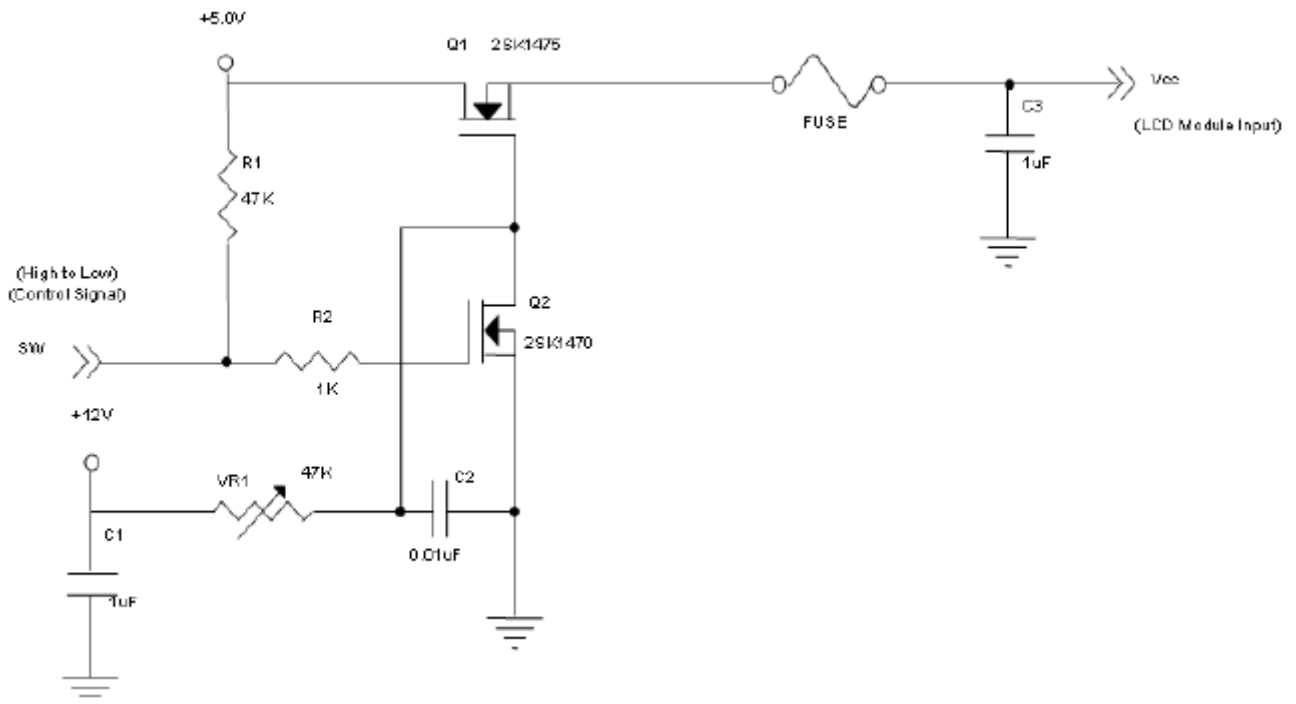
3. ELECTRICAL CHARACTERISTICS

3.1 TFT LCD MODULE

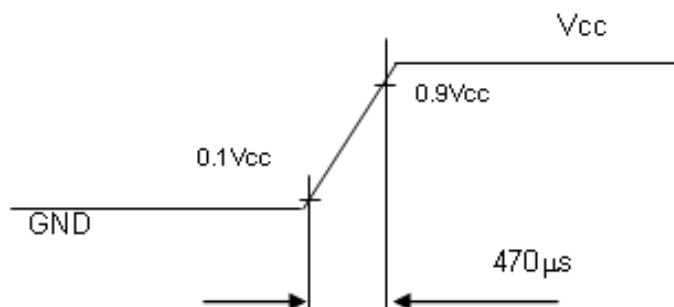
Parameter	Symbol	Value			Unit	Note
		Min.	Typ.	Max.		
Power Supply Voltage	V <sub>CC</sub>	4.5	5	5.5	V	-
Ripple Voltage	V <sub>RP</sub>	-	-	200	mVp-p	
Inrush Current	I <sub>NRUSH</sub>	-	-	3.0	A	(2)
Power Supply Current	White	-	0.64	0.73	A	(3)a
	Black	-	0.38	0.45	A	(3)b
LVDS differential input voltage	V <sub>id</sub>	100	-	600	mV	(4)
LVDS common input voltage	V <sub>ic</sub>	1.0	1.2	1.4	V	(4)
Differential Input Voltage for LVDS Receiver Threshold	"H" Level	-	-	100	mV	-
	"L" Level	-100	-	-	mV	-
Terminating Resistor	R <sub>T</sub>	-	100	-	Ohm	-

Note (1) The module should be always operated within above ranges.

Note (2) Measurement Conditions:



**Vcc rising time is 470μs**



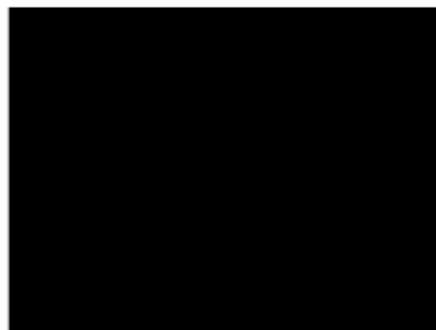
Note (3) The specified power supply current is under the conditions at  $V_{DD} = 5.0V$ ,  $T_a = 25 \pm 2^\circ C$ , DC Current and  $f_v = 60$  Hz, whereas a power dissipation check pattern below is displayed.

a. White Pattern



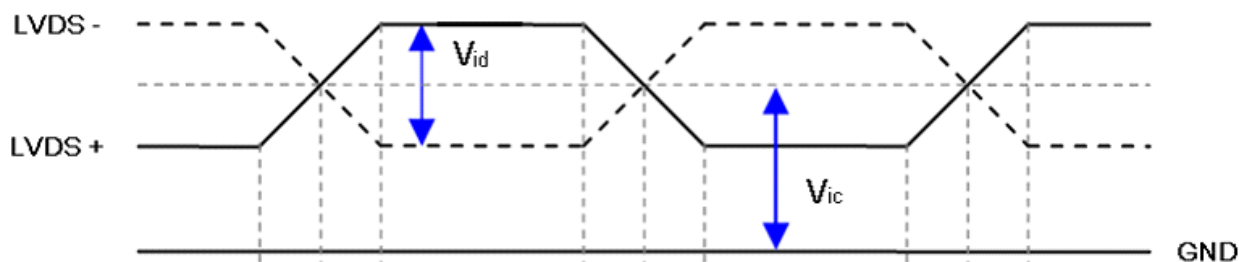
Active Area

b. Black Pattern



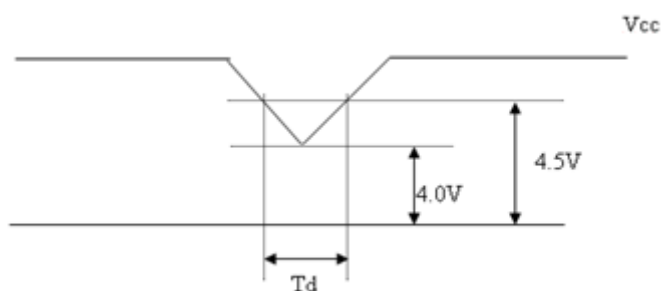
Active Area

Note (4) VID waveform condition



### 3.2 Vcc Power Dip Condition

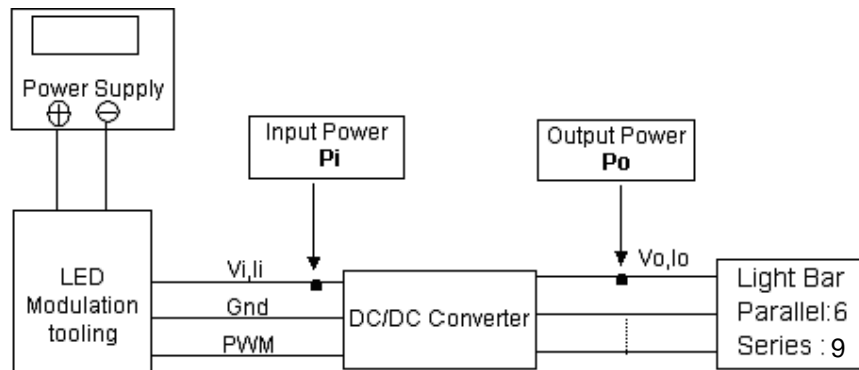
- Dip condition:  $4.0V \leq V_{cc} \leq 4.5V$ ,  $T_d \leq 20ms$



3.3 BACKLIGHT UNIT

Parameter	Symbol	Value			Unit	Note	
		Min.	Typ.	Max.			
Converter Input Voltage	$V_i$	10.8	12.0	13.2	V <sub>DC</sub>	(Duty 100%)	
Converter Input Ripple Voltage	$V_{IRP}$	-	-	500	mV		
Converter Input Current	$I_i$	0.7	0.8	0.9	A <sub>DC</sub>	@ $V_i = 12V$ (Duty 100%)	
Converter Inrush Current	$I_{IRUSH}$	-	-	3.0	A	@ $V_i$ rising time=10ms ( $V_i=12V$ )	
Input Power Consumption	$P_i$	8.4	9.6	10.8	W	(1)	
EN Control Level	Backlight on	ENLED	2.0	3.3	5.0	V	
	Backlight off	(BLON)	0	-	0.3	V	
PWM Control Level	PWM High Level	Dimming	2.0	-	5.0	V	
	PWM Low Level	(E_PWM)	0	-	0.15	V	
PWN Noise Range	$V_{Noise}$	-	-	0.1	V		
PWM Control Frequency	$f_{PWM}$	190	200	20k	Hz	(2)	
PWM Dimming Control Duty Ratio	-	-	5	-	100	%	(2), @ 190Hz < $f_{PWM}$ < 1kHz
			20	-	100	%	(2), @ 1kHz ≤ $f_{PWM}$ < 20kHz
LED Life Time	$L_{LED}$	50,000		-	Hrs	(3)	

Note (1) LED current is measured by utilizing a high frequency current meter as shown below:

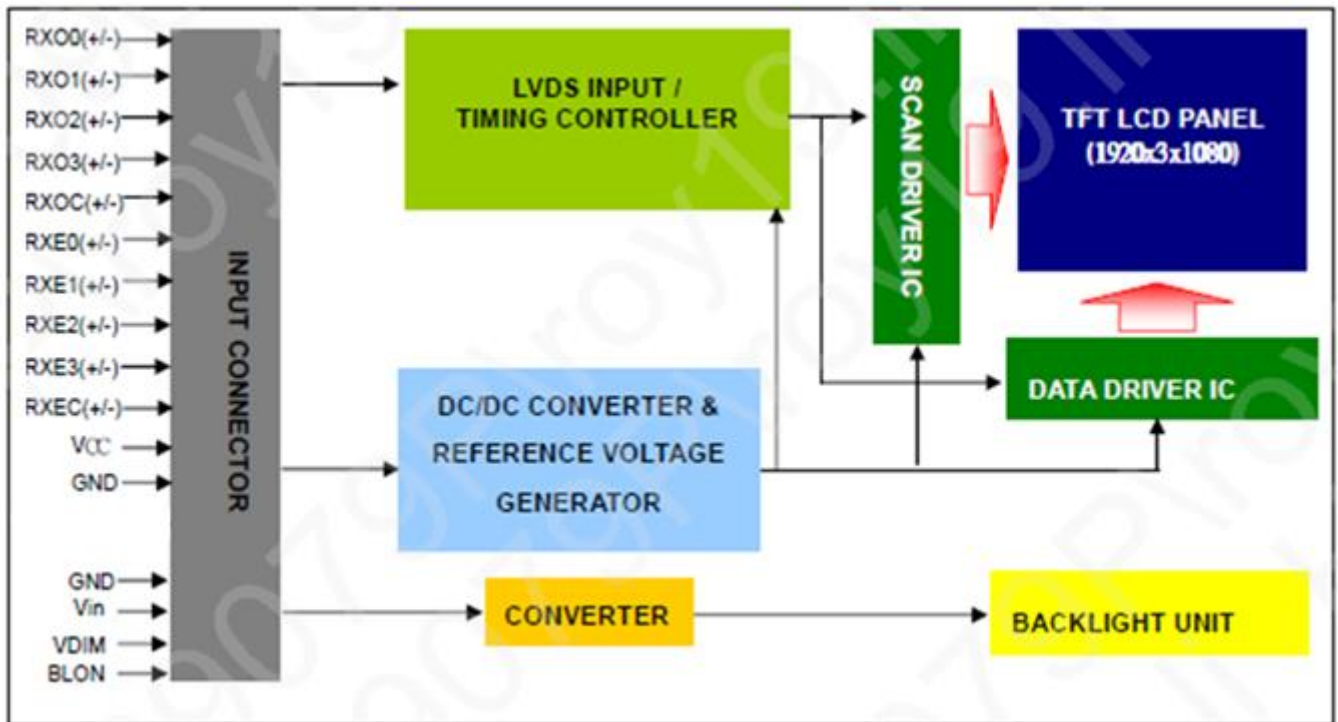


Note (2) The lifetime of LED is estimated data and defined as the time when it continues to operate under the conditions at  $T_a = 25 \pm 2 \text{ }^\circ\text{C}$  and Duty 100% until the brightness becomes  $\leq 50\%$  of its original value. Operating LED at high temperature condition will reduce life time and lead to color shift.

Note (3) At 190 ~1kHz PWM control frequency, duty ratio range is restricted from 5% to 100%. 1K ~20kHz PWM control frequency, duty ratio range is restricted from 20% to 100%. If PWM control frequency is applied in the range from 1KHz to 20KHz, The “non-linear” phenomenon on the Backlight Unit may be found. So It’ s a **suggestion** that PWM control frequency should be **less than 1KHz**.

4. BLOCK DIAGRAM

4.1 TFT LCD MODULE



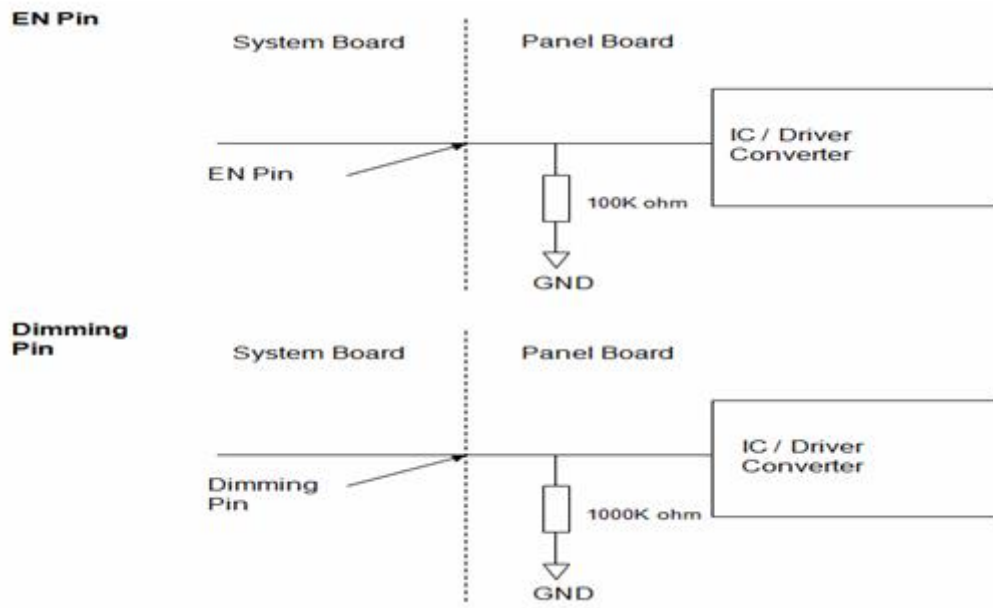
## 5. INPUT TERMINAL PIN ASSIGNMENT

### 5.1 TFT LCD MODULE

Pin	Name	Description	Note
1	LED_Vcc	+12V Vi power supply	-
2	LED_Vcc	+12V Vi power supply	-
3	LED_Vcc	+12V Vi power supply	-
4	LED_Vcc	+12V Vi power supply	-
5	GND	Ground	-
6	GND	Ground	-
7	GND	Ground	-
8	GND	Ground	-
9	LED_EN	Enable pin	-
10	LED_PWM	Backlight Adjust	-
11	LCD_VCC	LCD logic and driver power 5.0V	-
12	LCD_VCC	LCD logic and driver power 5.0V	-
13	LCD_VCC	LCD logic and driver power 5.0V	-
14	NC	Not connection, this pin should be open	-
15	NC	Not connection, this pin should be open	-
16	NC	Not connection, this pin should be open	-
17	NC	Not connection, this pin should be open	-
18	RX00-	Negative LVDS differential data input. Channel O0 (odd)	-
19	RX00+	Positive LVDS differential data input. Channel O0 (odd)	-
20	RX01-	Negative LVDS differential data input. Channel O1 (odd)	-
21	RX01+	Positive LVDS differential data input. Channel O1 (odd)	-
22	RX02-	Negative LVDS differential data input. Channel O2 (odd)	-
23	RX02+	Positive LVDS differential data input. Channel O2 (odd)	-
24	LCD GND	LCD logic and driver ground	-
25	RXOC-	Negative LVDS differential clock input. (odd)	-
26	RXOC+	Positive LVDS differential clock input. (odd)	-
27	LCD GND	LCD logic and driver ground	-
28	RX03-	Negative LVDS differential data input. Channel O3(odd)	-
29	RX03+	Positive LVDS differential data input. Channel O3 (odd)	-
30	RXE0-	Negative LVDS differential data input. Channel E0 (even)	-
31	RXE0+	Positive LVDS differential data input. Channel E0 (even)	-
32	RXE1-	Negative LVDS differential data input. Channel E1 (even)	-
33	RXE1+	Positive LVDS differential data input. Channel E1 (even)	-
34	LCD GND	LCD logic and driver ground	-
35	RXE2-	Negative LVDS differential data input. Channel E2 (even)	-
36	RXE2+	Positive LVDS differential data input. Channel E2 (even)	-
37	RXEC-	Negative LVDS differential clock input. (even)	-
38	RXEC+	Positive LVDS differential clock input. (even)	-
39	RXE3-	Negative LVDS differential data input. Channel E3 (even)	-
40	RXE3+	Positive LVDS differential data input. Channel E3 (even)	-

Note (1) Connector Part No.: I-PEX 20455-040E-76 or equivalent.

Note (2) User's connector Part No.: I-PEX 20453-040T-03 or equivalent.



## 5.2 COLOR DATA INPUT ASSIGNMENT

The brightness of each primary color (red, green and blue) is based on the 8-bit gray scale data input for the color. The higher the binary input the brighter the color. The table below provides the assignment of color versus data input.

Color		Data Signal																							
		Red								Green								Blue							
		R7	R6	R5	R4	R3	R2	R1	R0	G7	G6	G5	G4	G3	G2	G1	G0	B7	B6	B5	B4	B3	B2	B1	B0
Basic Colors	Black	0	0	0	0	0	0	0	0	0	0	0	0	0	0	0	0	0	0	0	0	0	0	0	0
	Red	1	1	1	1	1	1	1	1	0	0	0	0	0	0	0	0	0	0	0	0	0	0	0	0
	Green	0	0	0	0	0	0	0	0	1	1	1	1	1	1	1	1	0	0	0	0	0	0	0	0
	Blue	0	0	0	0	0	0	0	0	0	0	0	0	0	0	0	0	1	1	1	1	1	1	1	1
	Cyan	0	0	0	0	0	0	0	0	1	1	1	1	1	1	1	1	1	1	1	1	1	1	1	1
	Magenta	1	1	1	1	1	1	1	1	0	0	0	0	0	0	0	0	1	1	1	1	1	1	1	1
	Yellow	1	1	1	1	1	1	1	1	1	1	1	1	1	1	1	1	0	0	0	0	0	0	0	0
	White	1	1	1	1	1	1	1	1	1	1	1	1	1	1	1	1	1	1	1	1	1	1	1	1
Gray Scale Of Red	Red(0) / Dark	0	0	0	0	0	0	0	0	0	0	0	0	0	0	0	0	0	0	0	0	0	0	0	
	Red(1)	0	0	0	0	0	0	0	1	0	0	0	0	0	0	0	0	0	0	0	0	0	0	0	
	Red(2)	0	0	0	0	0	0	1	0	0	0	0	0	0	0	0	0	0	0	0	0	0	0	0	
	⋮	⋮	⋮	⋮	⋮	⋮	⋮	⋮	⋮	⋮	⋮	⋮	⋮	⋮	⋮	⋮	⋮	⋮	⋮	⋮	⋮	⋮	⋮		
	⋮	⋮	⋮	⋮	⋮	⋮	⋮	⋮	⋮	⋮	⋮	⋮	⋮	⋮	⋮	⋮	⋮	⋮	⋮	⋮	⋮	⋮	⋮		
	Red(253)	1	1	1	1	1	1	0	1	0	0	0	0	0	0	0	0	0	0	0	0	0	0	0	
	Red(254)	1	1	1	1	1	1	1	0	0	0	0	0	0	0	0	0	0	0	0	0	0	0	0	
	Red(255)	1	1	1	1	1	1	1	1	0	0	0	0	0	0	0	0	0	0	0	0	0	0	0	
Gray Scale Of Green	Green(0)/Dark	0	0	0	0	0	0	0	0	0	0	0	0	0	0	0	0	0	0	0	0	0	0	0	
	Green(1)	0	0	0	0	0	0	0	0	0	0	0	0	0	0	0	1	0	0	0	0	0	0	0	
	Green(2)	0	0	0	0	0	0	0	0	0	0	0	0	0	0	1	0	0	0	0	0	0	0	0	
	⋮	⋮	⋮	⋮	⋮	⋮	⋮	⋮	⋮	⋮	⋮	⋮	⋮	⋮	⋮	⋮	⋮	⋮	⋮	⋮	⋮	⋮	⋮		
	⋮	⋮	⋮	⋮	⋮	⋮	⋮	⋮	⋮	⋮	⋮	⋮	⋮	⋮	⋮	⋮	⋮	⋮	⋮	⋮	⋮	⋮	⋮		
	Green(253)	0	0	0	0	0	0	0	0	1	1	1	1	1	1	0	1	0	0	0	0	0	0	0	
	Green(254)	0	0	0	0	0	0	0	0	1	1	1	1	1	1	1	0	0	0	0	0	0	0	0	
	Green(255)	0	0	0	0	0	0	0	0	1	1	1	1	1	1	1	1	0	0	0	0	0	0	0	
Gray Scale Of Blue	Blue(0) / Dark	0	0	0	0	0	0	0	0	0	0	0	0	0	0	0	0	0	0	0	0	0	0	0	
	Blue(1)	0	0	0	0	0	0	0	0	0	0	0	0	0	0	0	0	0	0	0	0	0	0	1	
	Blue(2)	0	0	0	0	0	0	0	0	0	0	0	0	0	0	0	0	0	0	0	0	0	0	1	
	⋮	⋮	⋮	⋮	⋮	⋮	⋮	⋮	⋮	⋮	⋮	⋮	⋮	⋮	⋮	⋮	⋮	⋮	⋮	⋮	⋮	⋮	⋮		
	⋮	⋮	⋮	⋮	⋮	⋮	⋮	⋮	⋮	⋮	⋮	⋮	⋮	⋮	⋮	⋮	⋮	⋮	⋮	⋮	⋮	⋮	⋮		
	Blue(253)	0	0	0	0	0	0	0	0	0	0	0	0	0	0	0	1	1	1	1	1	1	0	1	
	Blue(254)	0	0	0	0	0	0	0	0	0	0	0	0	0	0	0	1	1	1	1	1	1	1	0	
	Blue(255)	0	0	0	0	0	0	0	0	0	0	0	0	0	0	0	1	1	1	1	1	1	1	1	

Note (1)0: Low Level Voltage, 1: High Level Voltage

6. INTERFACE TIMING

6.1 INPUT SIGNAL TIMING SPECIFICATIONS

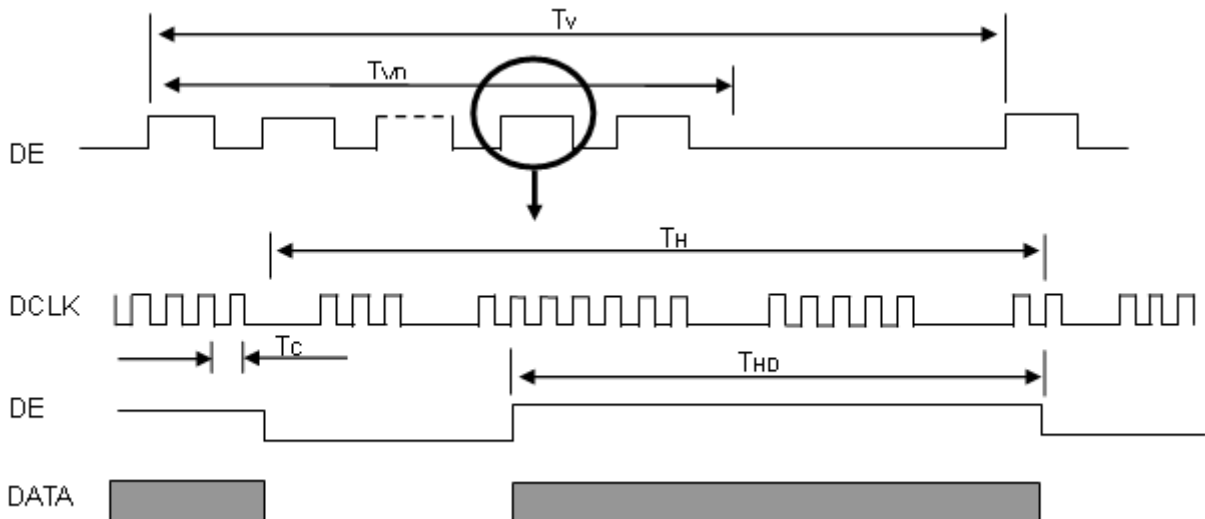
The input signal timing specifications are shown as the following table and timing diagram.

Signal	Item	Symbol	Min.	Typ.	Max.	Unit	Note
LVDS Clock	Frequency	$F_r$	60	70.93	75	MHz	-
	Period	$T_c$		14.1		ns	
	Input cycle to cycle jitter	$T_{rd}$	$-0.02 \cdot T_c$		$0.02 \cdot T_c$	ns	(3)
	Input Clock to data skew	TLVCCS	$-0.02 \cdot T_c$		$0.02 \cdot T_c$	ps	(4)
	Spread spectrum modulation range	$F_{clk_{in\_mod}}$	$FC \cdot 98\%$		$FC \cdot 102\%$	MHz	(5)
	Spread spectrum modulation frequency	$F_{SSM}$			200	KHz	
Vertical Display Term	Frame Rate	$F_r$	50	60	60	Hz	$T_v = T_{vd} + T_{vb}$
	Total	$T_v$	1090	1110	1130	$T_h$	-
	Active Display	$T_{vd}$	1080	1080	1080	$T_h$	-
	Blank	$T_{vb}$	$T_v - T_{vd}$	30	$T_v - T_{vd}$	$T_h$	-
Horizontal Display Term	Total	$T_h$	1050	1065	1075	$T_c$	$T_h = T_{hd} + T_{hb}$
	Active Display	$T_{hd}$	960	960	960	$T_c$	-
	Blank	$T_{hb}$	$T_h - T_{hd}$	105	$T_h - T_{hd}$	$T_c$	-

Note (1) Because this module is operated by DE only mode, Hsync and Vsync input signals should be set to low logic level or ground. Otherwise, this module would operate abnormally.

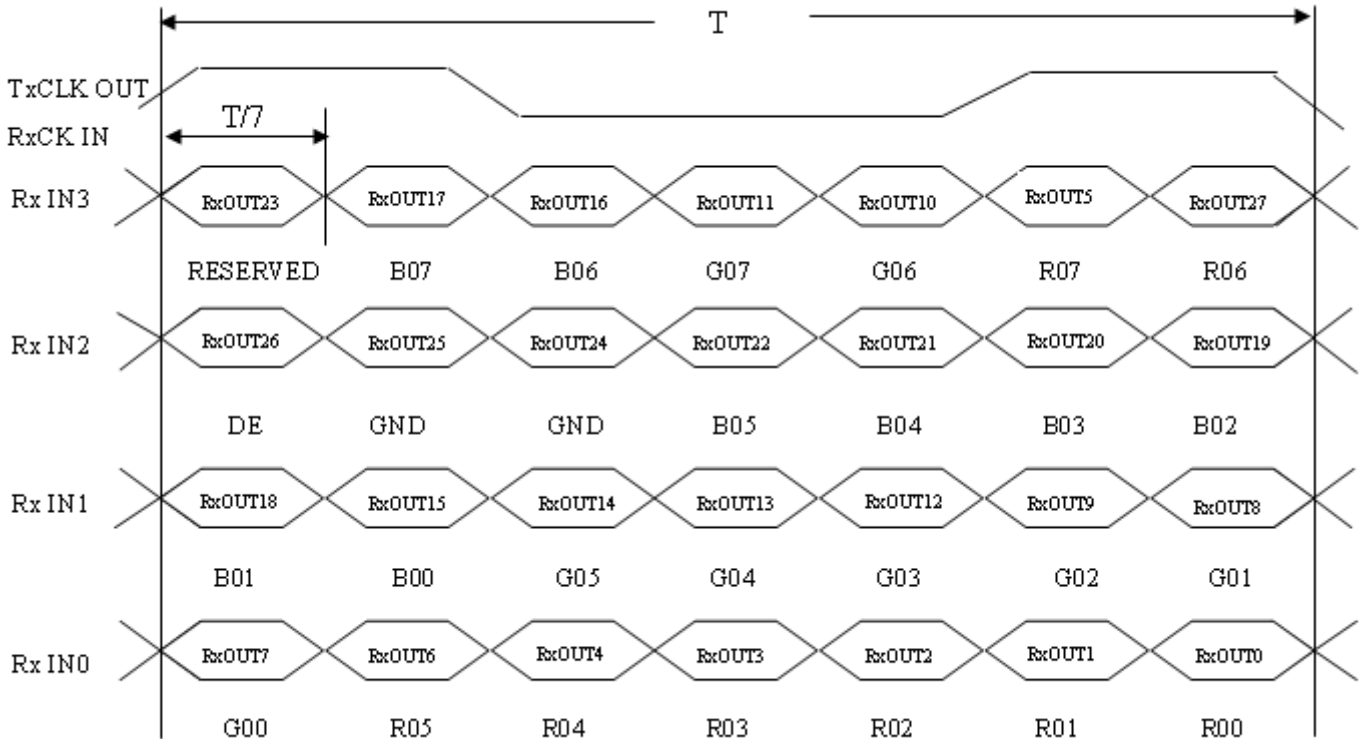
Note (2) The  $T_v(T_{vd} + T_{vb})$  must be integer, otherwise, the module would operate abnormally.

**INPUT SIGNAL TIMING DIAGRAM**

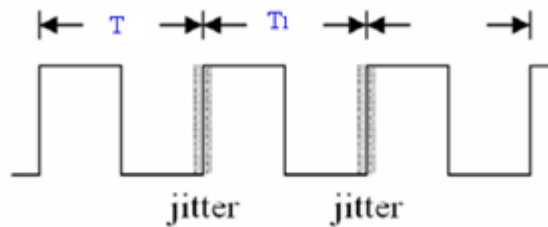




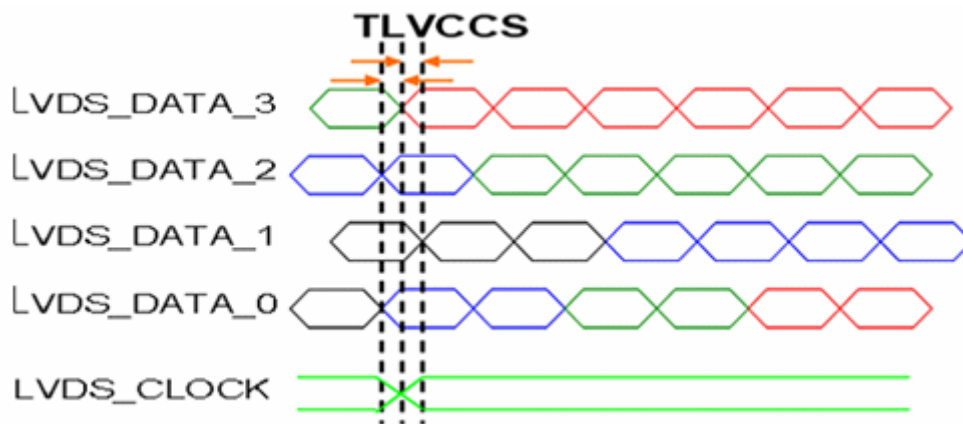
**TIMING DIAGRAM of LVDS**



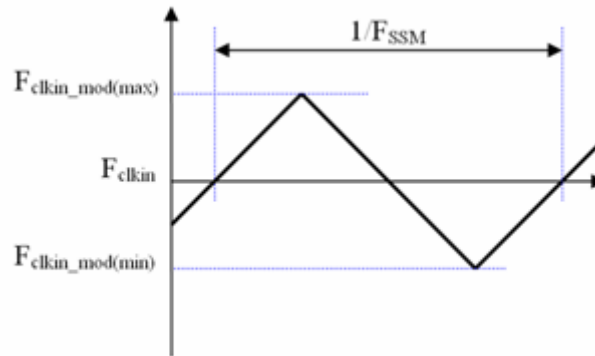
Note (3) The input clock cycle-to-cycle jitter is defined as below figures.  $T_{rd} = |T1 - T1|$



Note (4) Input Clock to data skew is defined as below figures.

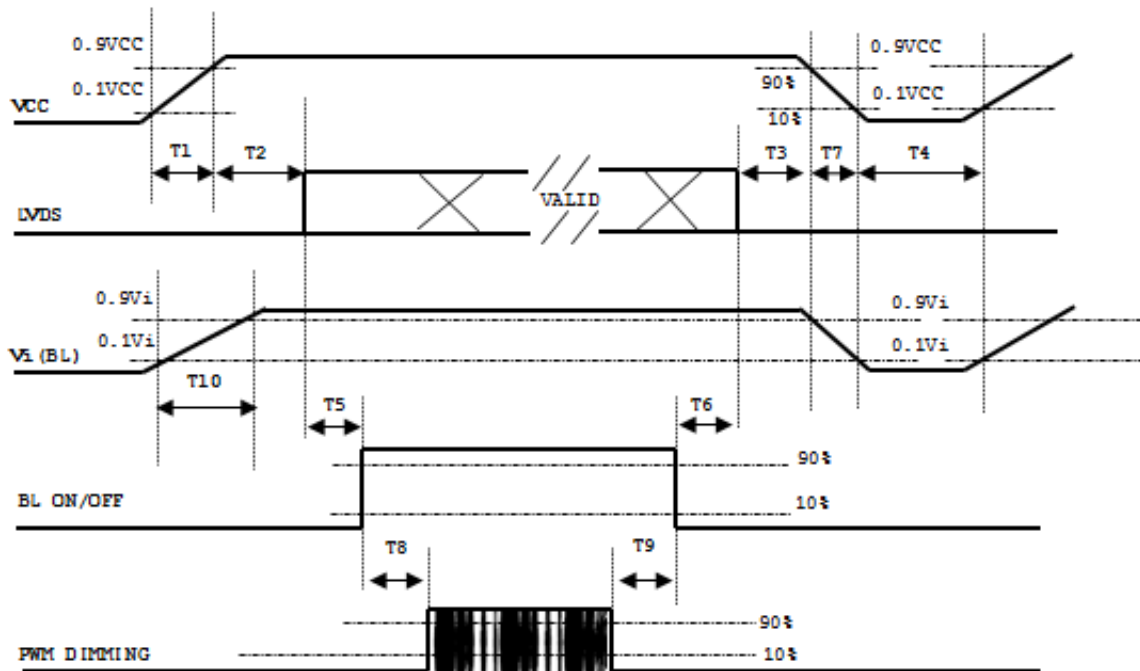


Note (5) The SSCG (Spread spectrum clock generator) is defined as below figures.



### 6.2 POWER ON/OFF SEQUENCE

To prevent a latch-up or DC operation of LCD assembly, the power on/off sequence should be as the diagram below.



Timing Specifications:

Parameter	Value			Units
	Min	Typ	Max	
T1	0.5	-	10	ms
T2	0	-	50	ms
T3	0	-	50	ms
T4	500	-	-	ms
T5	450	-	-	ms
T6	200	-	-	ms
T7	10	-	100	ms
T8	10	-	-	ms
T9	10	-	-	ms
T10	20	-	50	ms

Note:

- (1) The supply voltage of the external system for the module input should be the same as the definition of Vcc.
- (2) When the backlight turns on before the LCD operation of the LCD turns off, the display may momentarily become abnormal screen.
- (3) In case of VCC = off level, please keep the level of input signals on the low or keep a high impedance.
- (4) T4 should be measured after the module has been fully discharged between power off and on period.
- (5) Interface signal shall not be kept at high impedance when the power is on.
- (6) INX won't take any responsibility for the products which are damaged by the customers not following the Power Sequence.
- (7) There might be slight electronic noise when LCD is turned off (even backlight unit is also off). To avoid this symptom, we suggest "Vcc falling timing" to follow "T7 spec".

## 7. OPTICAL CHARACTERISTICS

### 7.1 TEST CONDITIONS

Item	Symbol	Value	Unit
Ambient Temperature	Ta	25±2	oC
Ambient Humidity	Ha	50±10	%RH
Supply Voltage	According to typical value and tolerance in "ELECTRICAL CHARACTERISTICS"		
Input Signal			
PWM Duty Ratio	D	100	%

### 7.2 OPTICAL SPECIFICATIONS

The relative measurement methods of optical characteristics are shown here and all items are measured at the center point of screen unless otherwise noted. The following items should be measured under the test conditions described above and stable conditions shown in Note (5).

Item	Symbol	Condition	Min.	Typ.	Max.	Unit	Note	
Color Chromaticity	Red	Rx	0.602	0.652	0.702	-	(1), (5)	
		Ry	0.288	0.338	0.388			
	Green	Gx	0.283	0.333	0.383			
		Gy	0.563	0.613	0.663			
	Blue	Bx	0.100	0.150	0.200			
		By	0.000	0.050	0.100			
	White	Wx	0.263	0.313	0.363			
		Wy	0.279	0.329	0.379			
Center Luminance of White	LC	Grayscale Maximum	400	500			(4), (5)	
Contrast Ratio	CR		600	800			(2), (5)	
Response Time	TR	$\theta X=0^\circ, \theta Y=0^\circ$	-	14	19	-	(3)	
	TF		-	11	16	-		
White Variation	$\delta W$	$\theta X=0^\circ, \theta Y=0^\circ$	70		-	%	(5), (6)	
Viewing Angle	Horizontal	$\theta X+$	$CR \geq 10$	85	89	-	Deg.	(1), (5)
		$\theta X-$		85	89	-		
	Vertical	$\theta Y+$		85	89	-		
		$\theta Y-$		85	89	-		

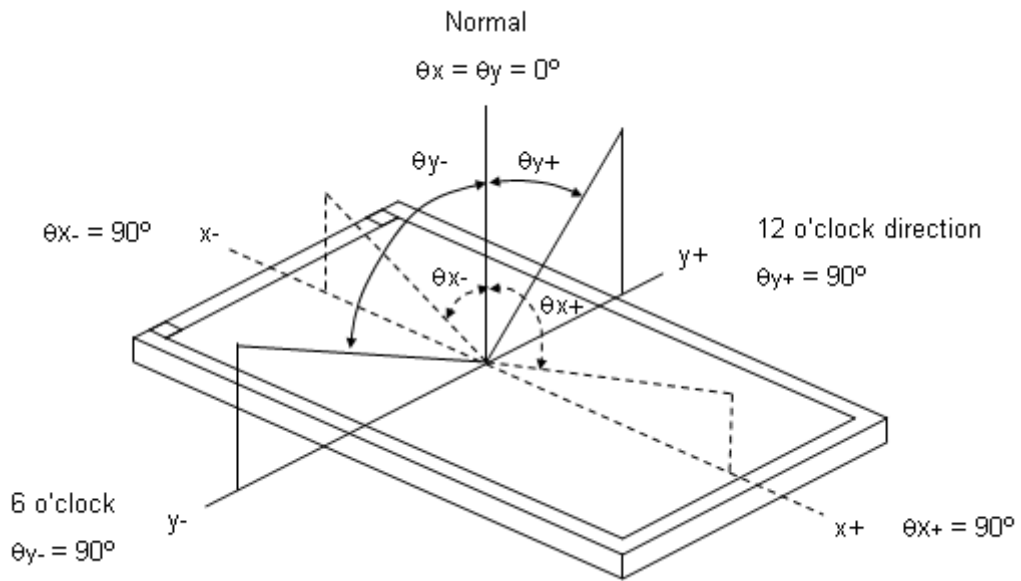
Definition :

Grayscale Maximum : Grayscale 255 (10 bits: grayscale 1023 ; 8 bits : grayscale 255 ; 6 bits: grayscale 63)

White : Luminance of Grayscale Maximum (All R,G,B)

Black : Luminance of grayscale 0 (All R,G,B)

Note (1) Definition of Viewing Angle ( $\theta_x, \theta_y$ ):

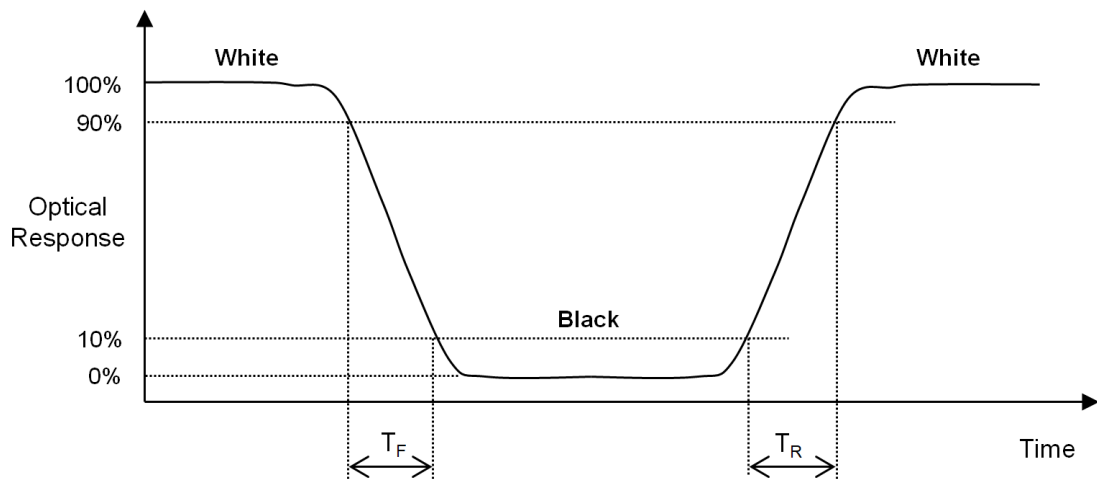


Note (2) Definition of Contrast Ratio (CR):

The contrast ratio can be calculated by the following expression at center point.

$$\text{Contrast Ratio (CR)} = \text{White} / \text{Black}$$

Note (3) Definition of Response Time ( $T_R, T_F$ ):

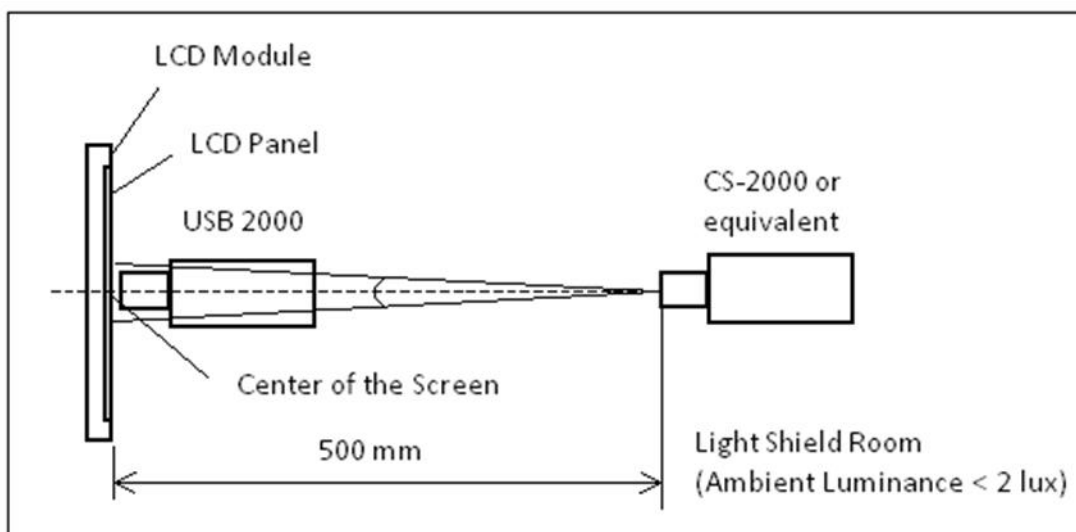


Note (4) Definition of Luminance of White (L<sub>c</sub>):

Measure the luminance of White at center point.

Note (5) Measurement Setup:

The LCD module should be stabilized at given temperature to avoid abrupt temperature change during measuring. In order to stabilize the luminance, the measurement should be executed after lighting Backlight for 40 minutes in a windless room. The measurement placement of module should be in accordance with module drawing.

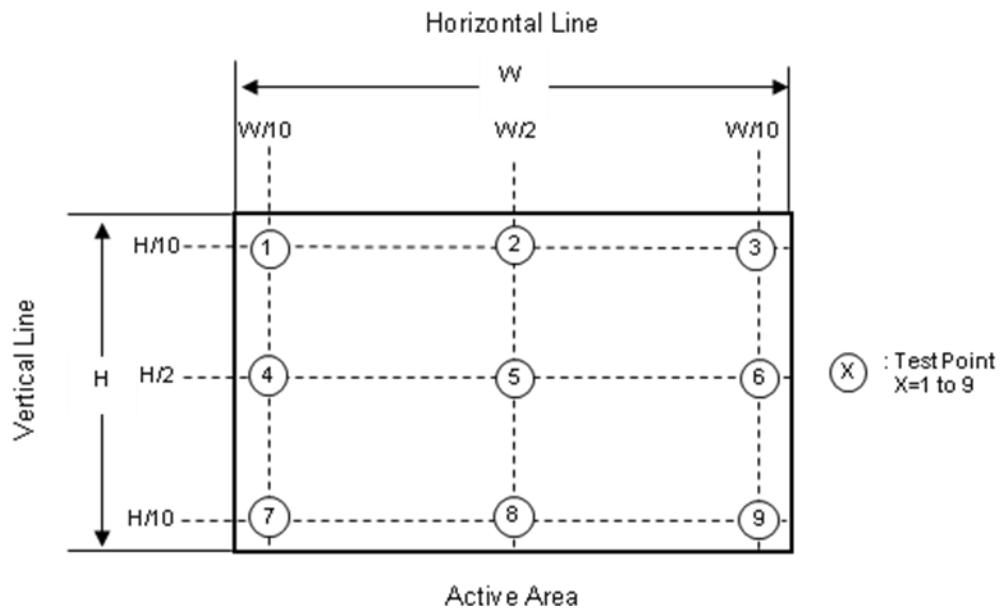


Note (6) Definition of White Variation (δW):

Measure the luminance of White at 9 points.

Luminance of White : L(X) , where X is from 1 to 9.

$$\delta W = \frac{\text{Minimum [ L(1) to L(9) ]}}{\text{Maximum [ L(1) to L(9) ]}} \times 100\%$$



## 8. RELIABILITY TEST CRITERIA

Test Item	Test Condition	Note
High Temperature Storage Test	70°C, 240 hours	(1),(2) (4),(5)
Low Temperature Storage Test	-30°C, 240 hours	
Thermal Shock Storage Test	-30°C, 0.5 hour ↔ 70°C, 0.5 hour; 100cycles, 1 hour/cycle)	
High Temperature Operation Test	70°C, 240 hours	
Low Temperature Operation Test	-20°C, 240 hours	
High Temperature & High Humidity Operation Test	60°C, RH 90%, 240 hours	
ESD Test (Operation)	150pF, 330Ω, 1 sec/cycle Condition 1 : panel contact, ±8 KV Condition 2 : panel non-contact ±15 KV	(1), (4)
Shock (Non-Operating)	50G, 11ms, half sine wave, 1 time for ± X, ± Y, ± Z direction	(2), (3)
Vibration (Non-Operating)	1.5G, 10 ~ 300 Hz sine wave, 30 min/cycle, 1 cycles each X, Y, Z direction	

Note (1) There should be no condensation on the surface of panel during test ,

Note (2) Temperature of panel display surface area should be 70°C Max.

Note (3) At testing Vibration and Shock, the fixture in holding the module has to be hard and rigid enough so that the module would not be twisted or bent by the fixture.

Note (4) In the standard conditions, there is no function failure issue occurred. All the cosmetic specification is judged before reliability test.

Note (5) Before cosmetic and function test, the product must have enough recovery time, at least 24 hours at room temperature.

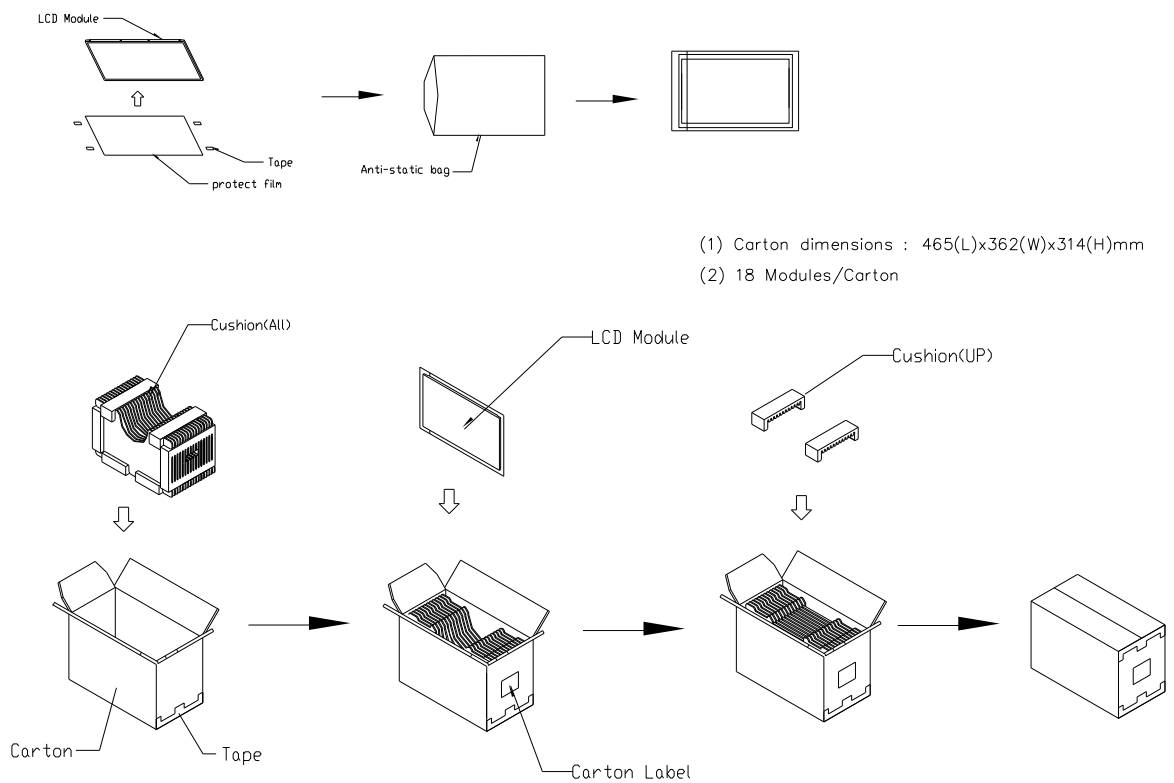


**9. PACKAGING**

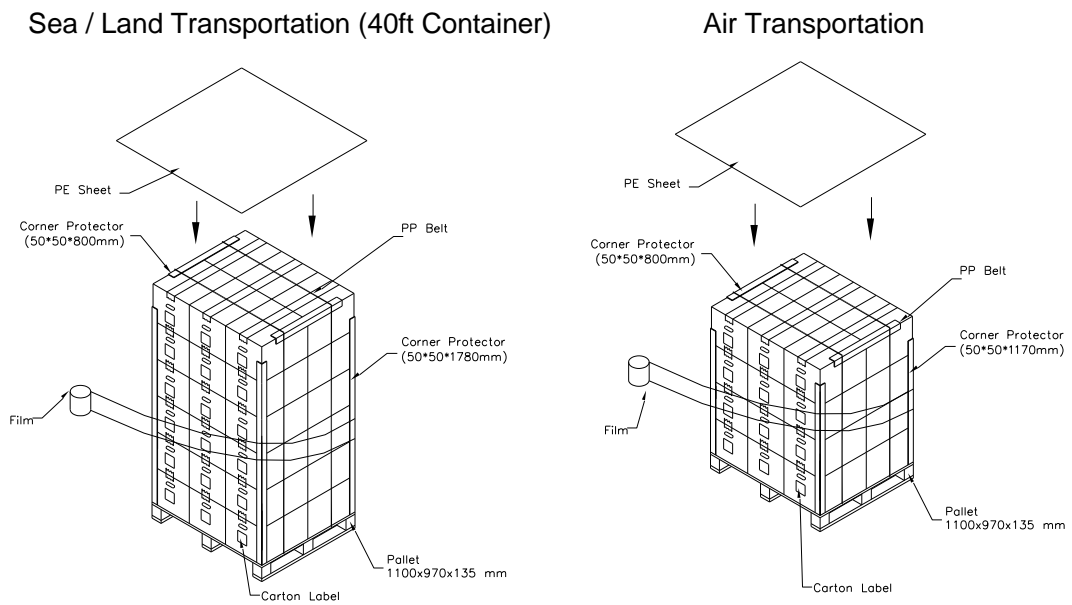
**9.1 PACKING SPECIFICATIONS**

- (1) 18pcs LCD modules / 1 Box
- (2) Box dimensions: 465 (L) X 362 (W) X 314 (H) mm
- (3) Weight: approximately 13.2Kg (18 modules per box)

**9.2 PACKING METHOD**

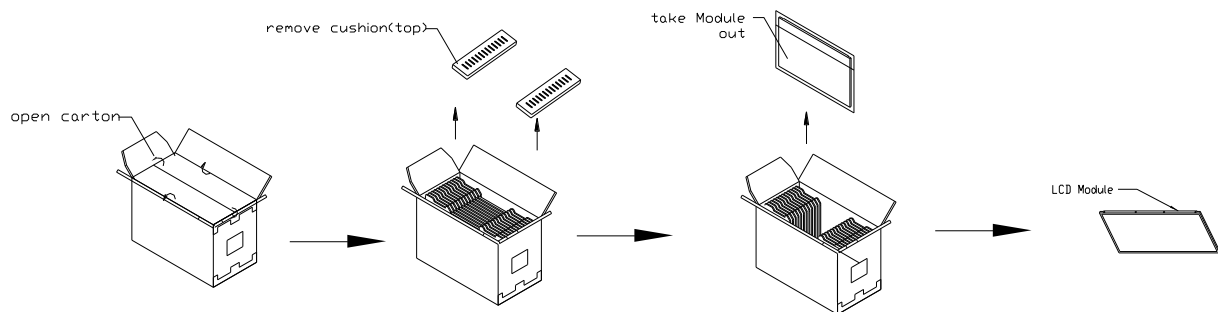


**Figure. 9-1 Packing method**



**Figure. 9-2 Packing method**

**9.3 UN-PACKING METHOD**

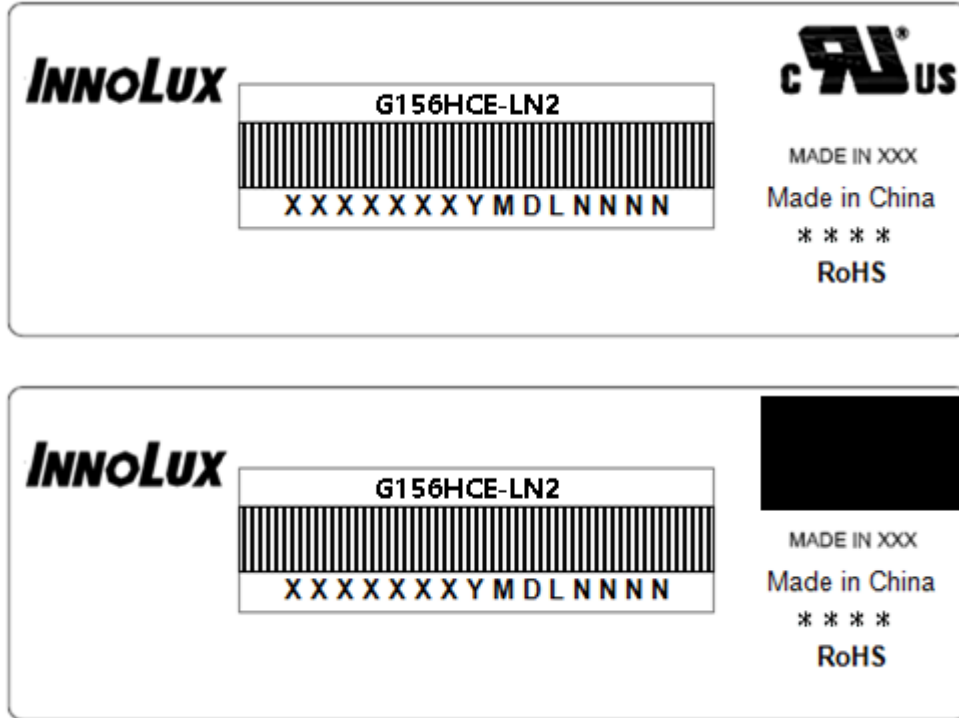


**Figure. 9-3 UN-Packing method**

10. DEFINITION OF LABELS

10.1 INX MODULE LABEL

The barcode nameplate is pasted on each module as illustration, and its definitions are as following explanation.

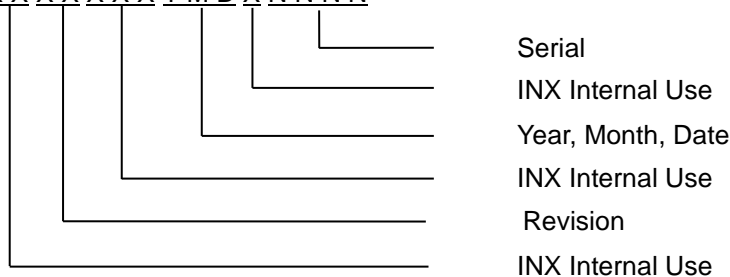


Note (1) Safety Compliance(UL logo) will open after C1 version.

(a)Model Name: G156HCE-LN2

(b)\* \* \* \* : Factory ID

(c)Serial ID: X X X X X X Y M D X N N N N



Serial ID includes the information as below:

- (a) Manufactured Date: Year: 1~9, for 2021~2029  
Month: 1~9, A~C, for Jan. ~ Dec.  
Day: 1~9, A~Y, for 1<sup>st</sup> to 31<sup>st</sup>, exclude I , O and U
- (b) Revision Code: cover all the change
- (c) Serial No.: Manufacturing sequence of product

**11. PRECAUTIONS****11.1 ASSEMBLY AND HANDLING PRECAUTIONS**

- (1) The module should be assembled into the system firmly by using every mounting hole. Be careful not to twist or bend the module.
- (2) While assembling or installing modules, it can only be in the clean area. The dust and oil may cause electrical short or damage the polarizer.
- (3) Use fingerstalls or soft gloves in order to keep display clean during the incoming inspection and assembly process.
- (4) Do not press or scratch the surface harder than a HB pencil lead on the panel because the polarizer is very soft and easily scratched.
- (5) If the surface of the polarizer is dirty, please clean it by some absorbent cotton or soft cloth. Do not use Ketone type materials (ex. Acetone), Ethyl alcohol, Toluene, Ethyl acid or Methyl chloride. It might permanently damage the polarizer due to chemical reaction.
- (6) Wipe off water droplets or oil immediately. Staining and discoloration may occur if they left on panel for a long time.
- (7) If the liquid crystal material leaks from the panel, it should be kept away from the eyes or mouth. In case of contacting with hands, legs or clothes, it must be washed away thoroughly with soap.
- (8) Protect the module from static electricity, it may cause damage to the C-MOS Gate Array IC.
- (9) Do not disassemble the module.
- (10) Do not pull or fold the lamp wire.
- (11) Pins of I/F connector should not be touched directly with bare hands.

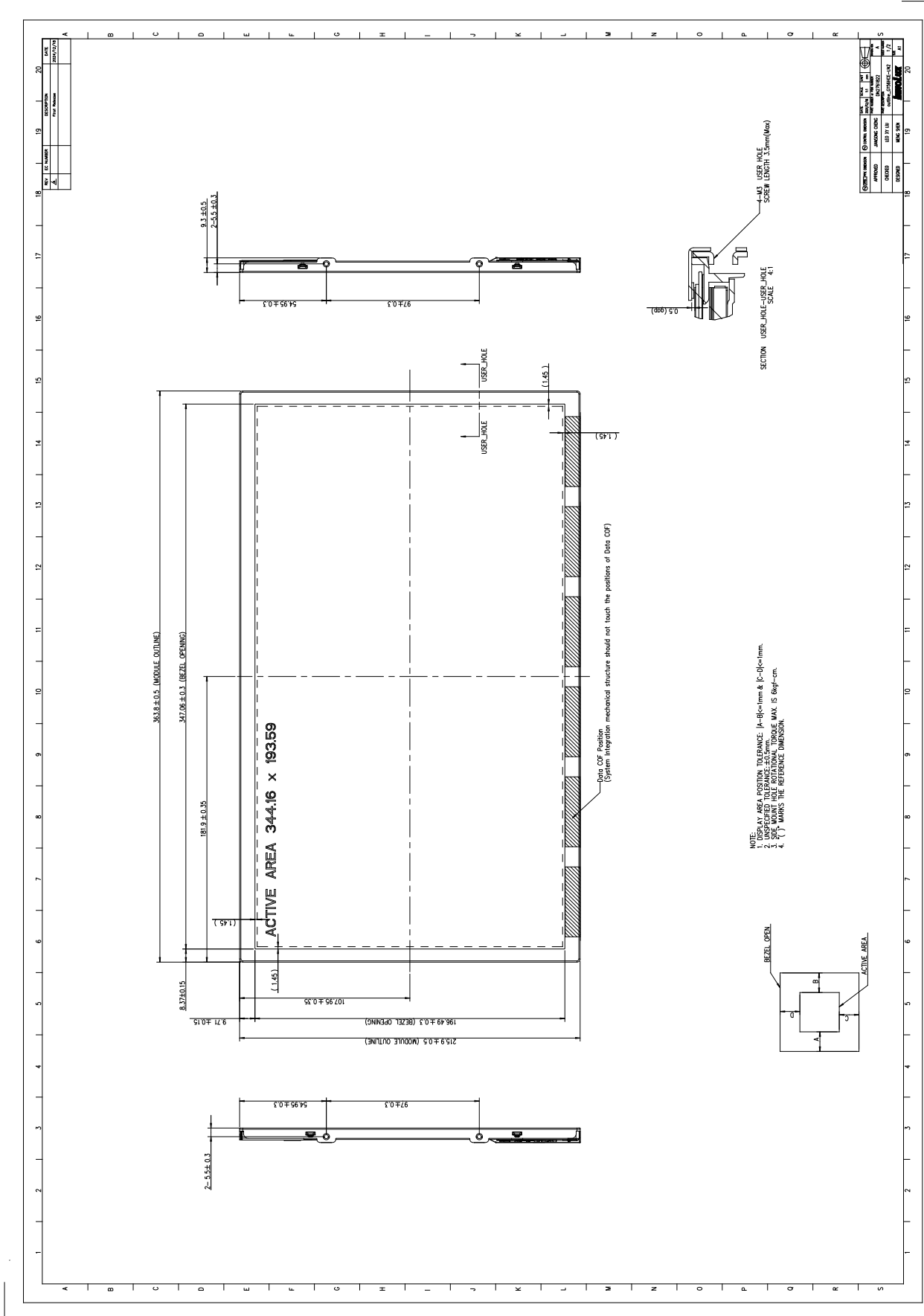
**11.2 STORAGE PRECAUTIONS**

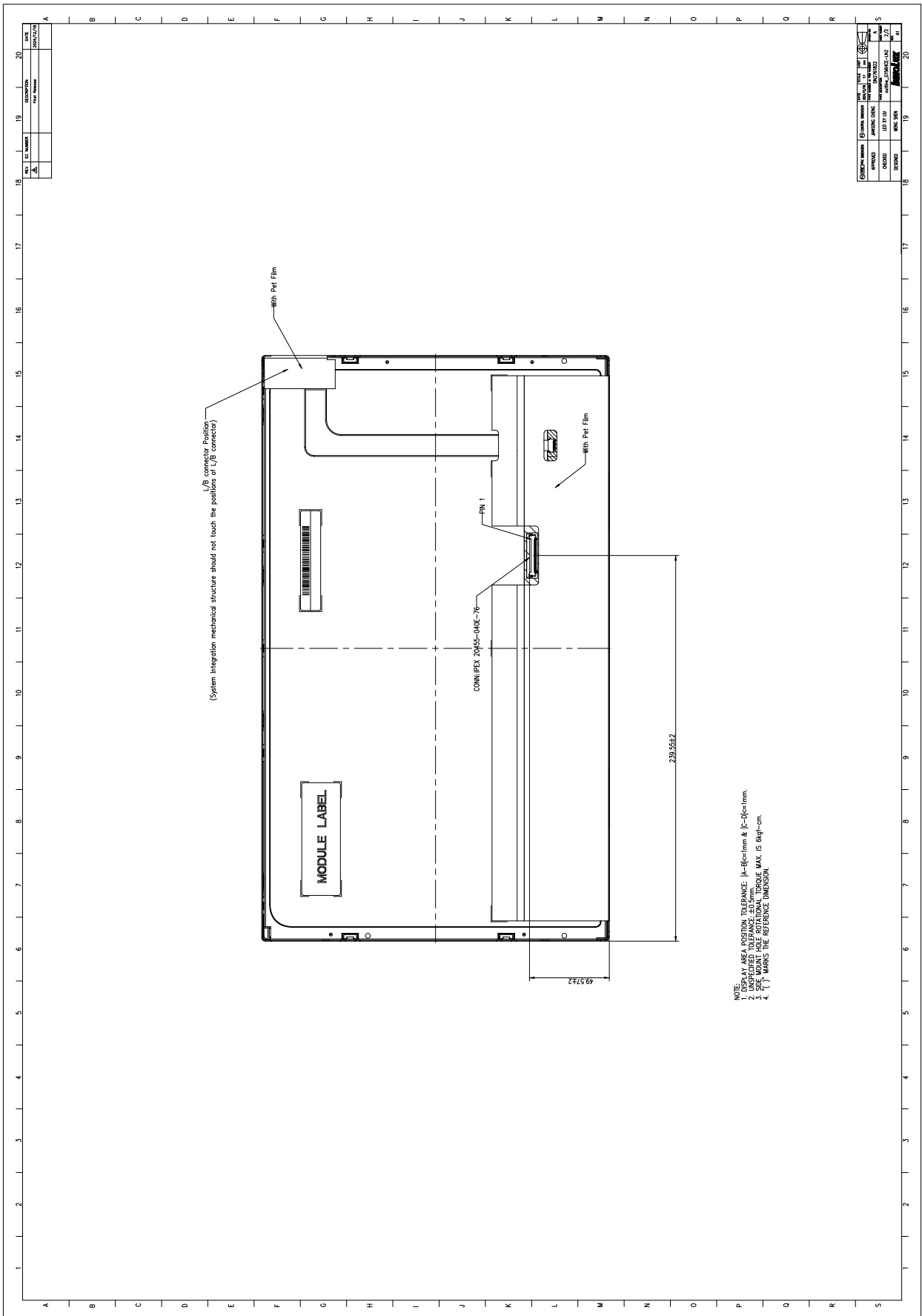
- (1) When storing for a long time, the following precautions are necessary.
  - (a) Store them in a dark place. Do not expose the module to sunlight or fluorescent light. Keep the temperature between 5°C and 30°C at humidity 50+-10%RH.
  - (b) The polarizer surface should not come in contact with any other object.
  - (c) It is recommended that they be stored in the container in which they were shipped.
  - (d) Storage condition is guaranteed under packing conditions.
  - (e) The phase transition of Liquid Crystal in the condition of the low or high storage temperature will be recovered when the LCD module returns to the normal condition
- (2) High temperature or humidity may reduce the performance of module. Please store LCD module within the specified storage conditions.
- (3) It is dangerous that moisture come into or contacted the LCD module, because the moisture may damage LCD module when it is operating.
- (4) It may reduce the display quality if the ambient temperature is lower than 10 °C. For example, the response time will become slowly, and the starting voltage of lamp will be higher than the room temperature.

### 11.3 OTHER PRECAUTIONS

- (1) Normal operating condition
  - (a) Display pattern: dynamic pattern (Real display)
    - (Note) Long-term static display can cause image sticking.
- (2) Operating usages to protect against image sticking due to long-term static display
  - (a) Static information display recommended to use with moving image.
- (3) Abnormal condition just means conditions except normal condition.


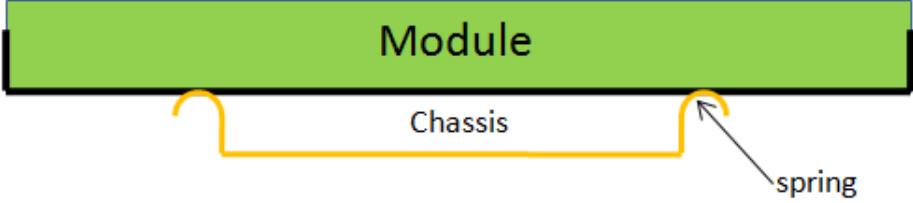

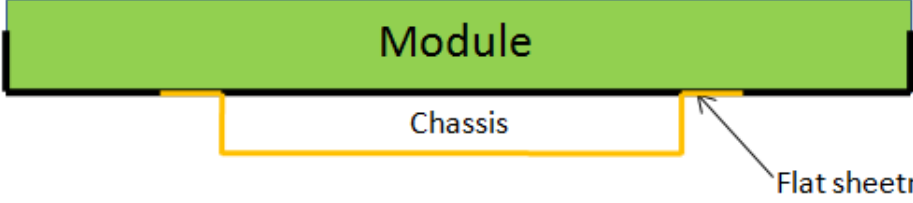

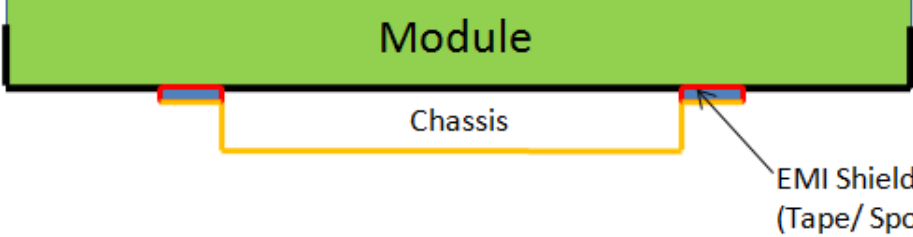
**12. MECHANICAL CHARACTERISTICS**





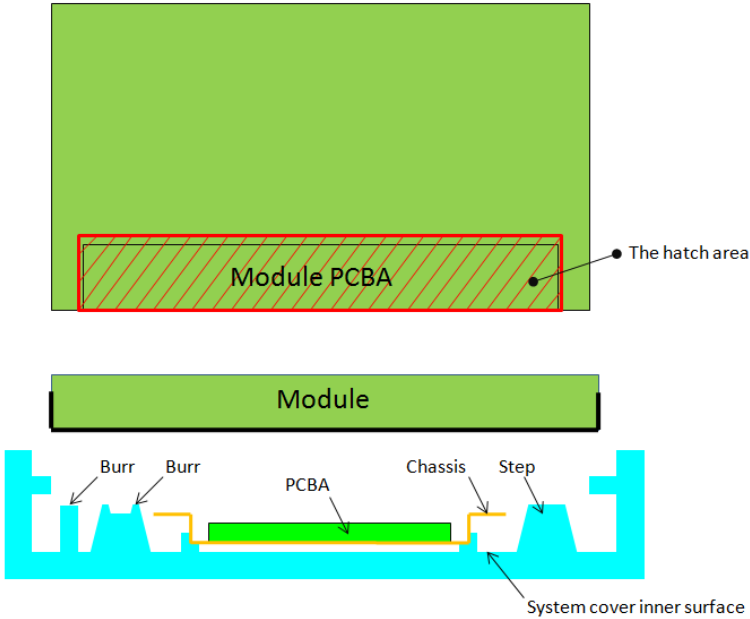
NOTE:  
 1. DISPLAY AREA POSITION TOLERANCE: (A-B)≤-0.1mm & (C-D)≤-0.1mm.  
 2. UNSPECIFIED DIMENSIONS ARE TO BE MANUFACTURED TO THE MAX. IS 6891-001.  
 3. DIMENSIONS IN PARENTHESES ARE FOR REFERENCE ONLY.  
 4. ( ) MARKS THE REFERENCE DIMENSION.

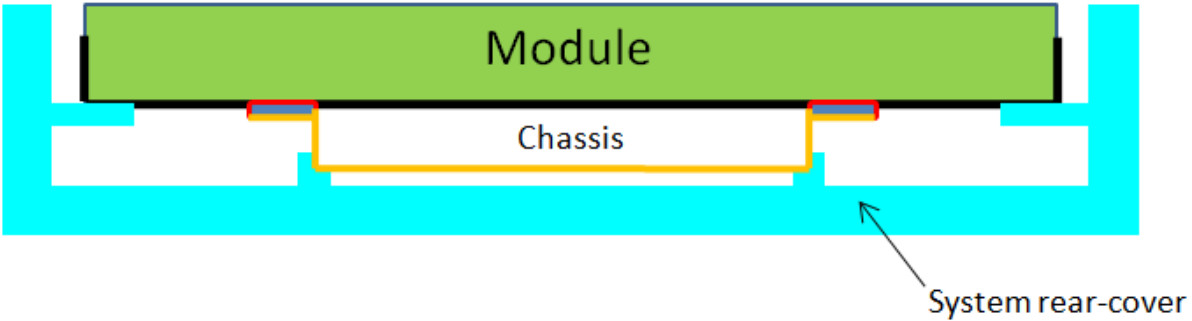
Appendix. SYSTEM COVER DESIGN NOTICE

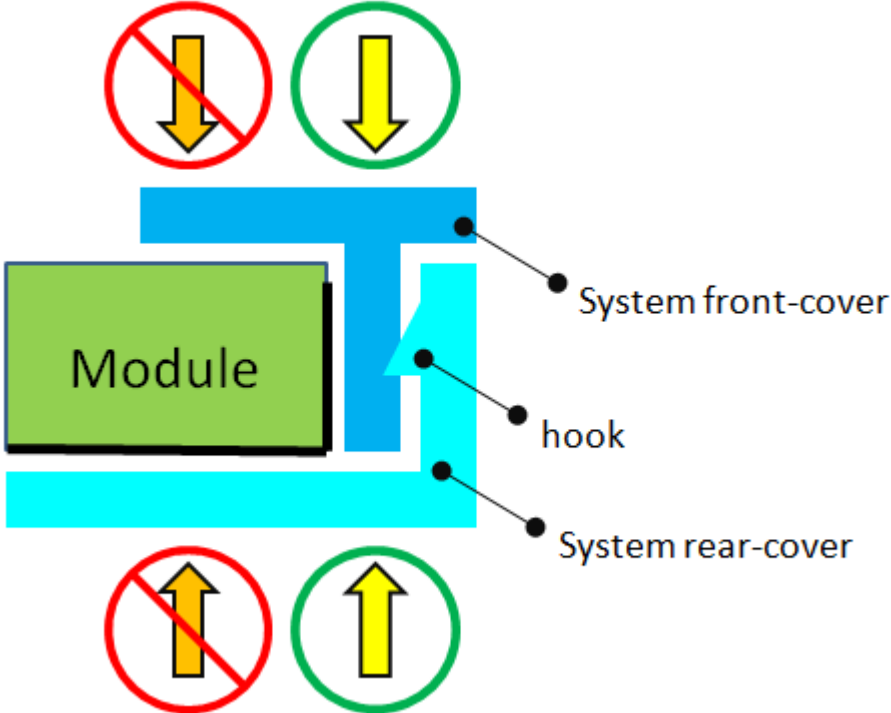
1	Set Chassis and IA Module touching Mode
	 <p>Module</p> <p>Chassis</p> <p>spring</p>
	 <p>Module</p> <p>Chassis</p> <p>Flat sheet metal</p>
	 <p>Module</p> <p>Chassis</p> <p>EMI Shielding Gasket (Tape/ Sponge)</p>
<p>Definition</p>	<p>a. To prevent from abnormal display &amp; white spot after mechanical test, it is not recommended to use spring type chassis.</p> <p>b. We suggest the contact mode between Chassis and Module rear cover is Tape/Sponge, second is Flat sheet metal type chassis.</p>

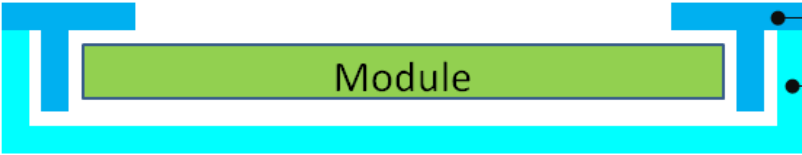
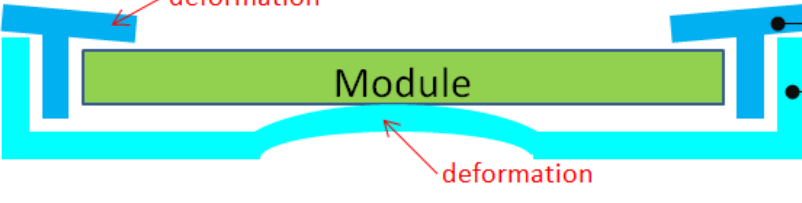
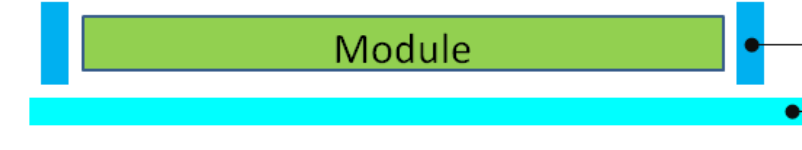
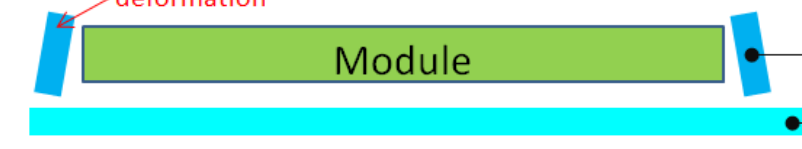
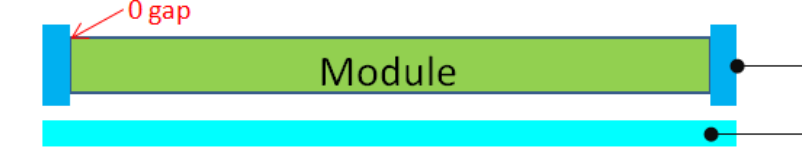
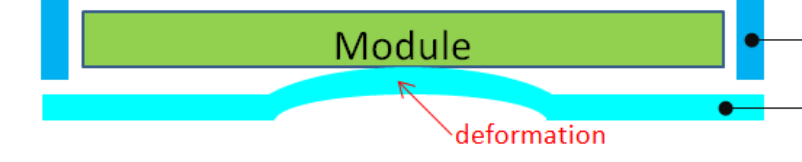


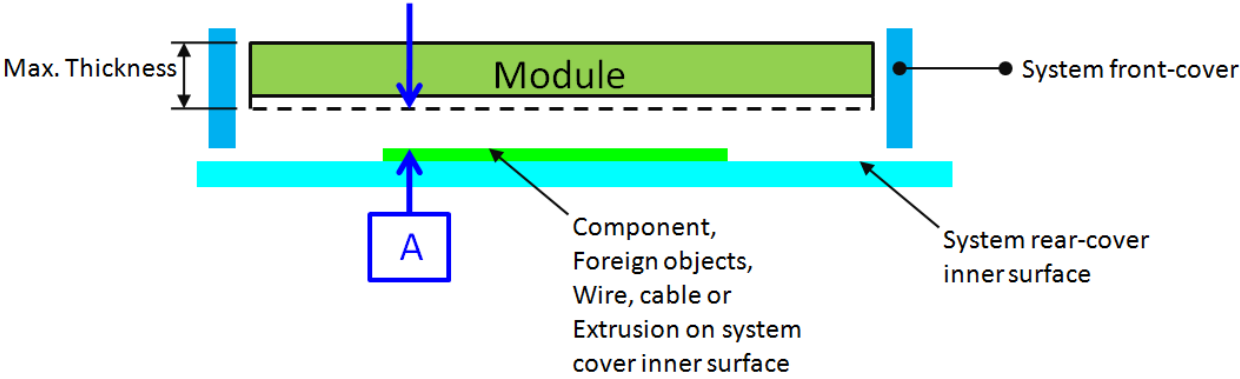
2	Tape/Sponge design on system inner surface
<p>The top diagram is a cross-sectional view showing a green 'Module' mounted on a yellow 'Chassis'. A cyan 'System rear bezel' is visible on the right. Red lines represent 'Tape/Sponge' applied between the module and chassis. Below this are two top-down views of the module area. The first view, marked with a red 'X', shows two separate red L-shaped 'Tape/Sponge' pieces. The second view, marked with a blue circle, shows a single red square 'Tape/Sponge' piece covering the entire module area.</p>	
Definition	<p>a. To prevent from abnormal display &amp; white spot after mechanical test, we suggest using Tape/Sponge as medium between chassis and Module rear cover could reduce the occurrence of white spot.</p> <p>b. When using the Tape/Sponge, we suggest it be lay over between set chassis and Module rear cover. It is not recommended to add Tape/Sponge in separate location. Since each Tape/Sponge may act as pressure concentration location.</p>

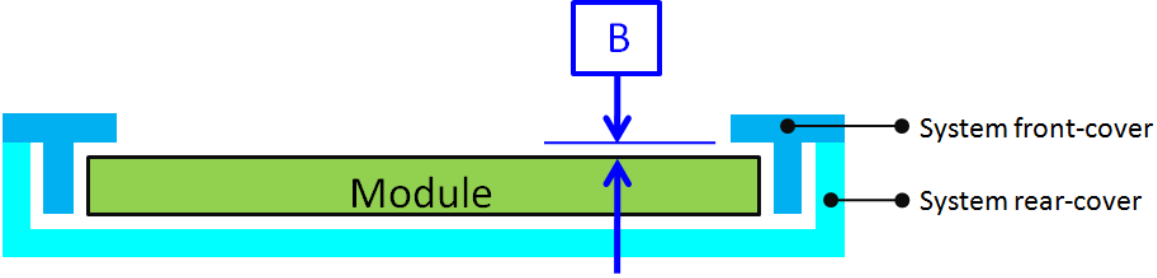
3	<b>System inner surface examination</b>
	
Definition	<p>a. The hatch area on Module PCBA should keep at least 1mm gap(X,Y,Z direction) to any structure with system cover inner surface.</p> <p>b. Burr, Step, PCB protrusion may cause stress concentration. White spot may occur during reliability test.</p>

4	<b>Material used for system rear-cover</b>
	
Definition	<p>System rear-cover material with high rigidity is needed to resist deformation during scuffing test, hinge test, pogo test or backpack test. Abnormal display, white spot, pooling issue may occur if low rigidity material is used. Pooling issue may occur because screw's boss position for module's bracket are deformed open-close test. Solid structure design of system rear-cover may also influence the rigidity of system rear-cover. The deformation of system rear-cover should not caused interference.</p>

5	Assembly SOP examination for system front-cover with hook structure
	
Definition	To prevent panel crack during system front-cover assembly process with hook structure, it is not recommended to press panel or any location that relate directly to the panel.

6	Permanent deformation of system cover after reliability test
○	 <ul style="list-style-type: none"> <li>● System front-cover</li> <li>● System rear-cover</li> </ul>
✗	 <ul style="list-style-type: none"> <li>● System front-cover</li> <li>● System rear-cover</li> </ul>
○	 <ul style="list-style-type: none"> <li>● System front-cover</li> <li>● System rear-cover</li> </ul>
✗	 <ul style="list-style-type: none"> <li>● System front-cover</li> <li>● System rear-cover</li> </ul>
✗	 <ul style="list-style-type: none"> <li>● System front-cover</li> <li>● System rear-cover</li> </ul>
✗	 <ul style="list-style-type: none"> <li>● System front-cover</li> <li>● System rear-cover</li> </ul>
Definition	<p>System cover including front cover and rear cover may deform during reliability test. Permanent deformation of system front cover and rear cover after reliability test should not interfere with panel. Because it may cause issue such as pooling, abnormal display, white spot and also cell crack.</p> <p>Note: If the interference cannot be avoided, please feel free to contract INX FAE Engineer for collaboration design. We can help to verify and pass risk assessment for customer reference.</p>

7	<b>Design gap A between panel &amp; any components on system rear-cover</b>
	
Definition	<p>System cover including front cover and rear cover may deform during reliability test. Permanent deformation of system front cover and rear cover after reliability test should not interfere with panel. Because it may cause issue such as pooling, abnormal display, white spot and also cell crack.</p> <p>Note: If the interference cannot be avoided, please feel free to contract INX FAE Engineer for collaboration design. We can help to verify and pass risk assessment for customer reference.</p>

8	<b>Design gap B between system front-cover &amp; panel surface</b>
	
Definition	<p>Gap between system front-cover &amp; panel surface is needed to prevent pooling or glass broken. Zero gap or interference such as burr and warpage from mold frame may cause pooling issue near system front-cover opening edge. This phenomenon is obvious during swing test, hinge test, knock test or during pooling inspection procedure.</p> <p>To remain sufficient gap, design with system rib higher than maximum panel thickness is recommended.</p> <p>Note: If the interference cannot be avoided, please feel free to contract INX FAE Engineer for collaboration design. We can help to verify and pass risk assessment for customer reference.</p>

9	Design gap C between panel & system front-cover or protrusions
Definition	<p>Gap between panel &amp; system front-cover or protrusions is needed to prevent shock test failure. Because system front-cover or protrusions with small gap may hit panel during the test. Issue such as cell crack, abnormal display may occur.</p> <p>The gap should be large enough to absorb the maximum displacement during the test.</p> <p>Note: If the interference cannot be avoided, please feel free to contract INX FAE Engineer for collaboration design. We can help to verify and pass risk assessment for customer reference.</p>

10	Design distance between TP AA to LCD AA
Definition	TP VA should avoid TP ink area covering LCD AA or causing the module frame to be exposed.

11	<b>Use OCR Lamination</b>
<p>The diagram illustrates two methods of OCR lamination. The top method, marked with a red 'X', shows 'Line pooling' occurring at the edges of the 'TP or Cover Glass' layer. The bottom method, marked with a green circle, shows the 'TP or Cover Glass' layer with 'OCR' applied to the edges, and a detailed inset shows 'OCR overflow' and 'Add Side glue' at the edge of the module.</p>	
Definition	<ol style="list-style-type: none"> <li>1.OCR glue as possible beyond module, in order to avoid Line Pooling</li> <li>2.Add side glue to avoid Line Pooling</li> </ol>