

SPECIFICATION

[] Preliminary Specification
 [●] Final Specification

Description **8.4” 640xRGBx480 TFT-LCD Module**
Part Number **P0840VGF1MB00**

Customer	Product Dept, PDBU Tianma Microelectronics Co., Ltd.		
Signatures	Date	Approved By	Date
_____	_____	Kevin Kim	2025/6/4
_____	_____	Reviewed By	
		Longping Deng	2025/6/4
		Prepared By	
		Jane Gao	2025/6/4
Comments:			

* This cover page is for your Comments and Signatures back to TIANMA.

REVISION HISTORY

Rev	Date	Page	Revision Items	Editor
1.0	2023/11/15		Preliminary spec	Tingting Hou
1.1	2023/12/08		Add matching connector in page 3 Add Backlight Forward Current in page 5 Update Absolute Humidity Remark in page 5 Update backlight driving figure in page 6 Add chapter 5.3&5.4 in page 7 Delete repeat notes in page 7 Update CN1+CN2 in page 8 Update AC characteristics in page 9 Update Data Input Timing Parameter Setting in page 10 Update Chromaticity Condition in page 13	Tingting Hou
1.2	2023/12/15		Delete chapter 5.1&5.3&5.5 "VCC=5V" in page 6	Tingting Hou
1.3	2024/01/22		Add connector supplier in page 3&4 Update VCC in page 5 Update VCC MIN&MAX in page 6 Update LCD power on/off Note2 in page 7 Update Figure 6.1.1 and CLK cycle time in page 9 Update Note1&3 in page 10	Tingting Hou
1.4	2024/04/26		Update pin27、 pin32~39 description in page 3 Add CN2 matching connector in page 4 Update Fuse in page 7 Update Note 2 in page 8 Delete chapter 6.5 in page 12 Update Mechanical Drawing in page 17	Tingting Hou
1.5	2024/05/21		Update pin27、 pin32~40 description in page 3	Tingting Hou
1.6	2024/10/22		Update "TBD" and Mechanical Drawing in page 17	Tingting Hou
1.7	2024/11/13		Update "Supply Voltage" in page 6 Update "LCD Module Block Diagram" in page 9 Update "SYNC MODE" in page 11 Update "Timing Diagram" in page 12&13 Update "ESD test" in page 17 Update "Packing Instruction" in page 19	Tingting Hou
1.8	2024/12/05		Update "SYNC MODE" in page 11	Tingting Hou
1.9	2025/04/03		Update "3.1.3 Pin Assignment for LCD" in page 3&4 Update "Pin assignment for Back light" in page 4 Delete "Note 1" in page 6 Update "5.5.1 LCD power on/off" in page 7 Update "5.5.2 Backlight on/off" in page 8 Update "5.6 LCD Module Block Diagram" in page 9 Update "5.7 Display Color and input data signal" in page 10 Update "5.8 Display Positions" in page 11 Update "Figure 6.1.1"&"Table 6.1.1" in page 12 Update "6.2 SYNC MODE&DE MODE" in page 13 Update "Description for pin 3 (Hsync) and Pin 4 (Vsync)" in page 3 Added "2 Polarizer pencil-hardness" in page 2. Updated "8 Reliability Test" in page 19.	Jane Gao

Professional Display Module

2.0	2025/06/04		Updated "7 Optical Characteristic, chromaticity of white(x,y) in page16. Updated "7 Optical Characteristic, Luminance in page16.	Jane Gao
-----	------------	--	-------------------------------------------------------------------------------------------------------------------------------------	----------

CONTENTS

1. SUMMARY	1
1.1 General Description.....	1
1.2 Features.....	1
2. GENERAL SPECIFICATIONS	2
3. INPUT / OUTPUT TERMINALS	3
3.1 CN1 Pin assignment (LCD Interface).....	3
3.2 CN2 Pin assignment (Back Light).....	4
4. ABSOLUTE MAXIMUM RATINGS	5
5. ELECTRICAL CHARACTERISTICS	6
5.1 DC Characteristics for Panel Driving.....	6
5.2 Characteristics for Backlight Driving.....	6
5.3 Power supply voltage ripple.....	7
5.4 Fuse.....	7
5.5 Power ON/OFF Sequence.....	7
5.6 LCD Module Block Diagram.....	9
5.7 Display Colors And Input Data Signals.....	10
5.8 Display Positions.....	11
6. TIMING CHARACTERISTICS	12
6.1 AC characteristics.....	12
6.2 Data Input Timing Parameter Setting.....	13
6.3 SYNC Mode Timing Diagram.....	14
6.4 DE Mode Timing Diagram.....	15
7. OPTICAL CHARACTERISTICS	16
8. RELIABILITY TEST	19
9. MECHANICAL DRAWING	20
10. PACKING INSTRUCTION	21
11. PRECAUTIONS FOR USE OF LCD MODULES	23
11.1 Handling Precautions.....	23
11.2 Storage precautions.....	23
11.3 Transportation Precautions.....	23
11.4 Screen saver Precautions.....	23
11.5 Safety Precautions.....	23

1. Summary

1.1 General Description

This is a 8.4 inch a-Si TFT-LCD module with Normal- Black technology. It is composed of a TFT-LCD panel, a driver circuit, a PCB, and a LED backlight unit.

1.2 Features

- Ultra-wide viewing angle
- Long LED life time
- Wide temperature range
- Interface: RGB 6bits
- Anti- glare Surface treatment
- Acquisition product for UL62368-1/CSA C22.2 No.62368-1-03 (File number: E333987)
- Compliant with the European RoHS Directive (2011/65/EU) and Delegated Directive (2015/863/EU, Amending Annex II of 2011/65/EU)

2. General Specifications

	Feature	Spec	Unit
Display Spec	Size	8.4 inches	
	Resolution	640(RGB)x480	
	Pixel Pitch	0.267*0.267	mm
	TFT Active Area	170.88*128.16	mm
	Technology Type	a-Si	
	Pixel Configuration	R.G.B Vertical Stripe	
	Display Mode	SFT	
	Surface Treatment	Anti-Glare	
	Viewing Direction	ALL	
	Gray Scale Inversion Direction	No Gray Scale Inversion Direction	
	Polarizer absorption axis	Horizontal	
	Polarizer pencil-hardness	3H	
Mechanical Characteristics	LCM (W x H x D)	200*152*8.8	mm
	Weight	233	g
Optical Characteristics	Luminance	500	cd/m ²
	Contrast Ratio	1300	
	NTSC	50	%
	Viewing Angle	88/88/88/88	degree
Electrical Characteristics	Interface	RGB 6 bits	
	Color Depth	262K	color
	Power Consumption	LCD:148.5 Backlight:2175	mW

Table 2.1 General TFT Specifications

3. Input / Output Terminals

3.1 CN1 Pin assignment (LCD Interface)

Connector Information	
LCD Module connector	MSAK24025P40 (STM)
Matching connector	20453-240T-03(I-PEX) or equivalent

Table 3.1.1 Connector information

No	Symbol	I/O	Description	Comment
1	GND	P	Ground	-
2	CLK	I	Dot clock	-
3	Hsync	I	Horizontal synchronous signal, please tie H or L in DE mode	-
4	Vsync	I	Vertical synchronous signal, please tie H or L in DE mode	
5	GND	P	Ground	
6	R0	I	Red data	
7	R1	I	Red data	
8	R2	I	Red data	
9	R3	I	Red data	
10	R4	I	Red data	
11	R5	I	Red data	
12	GND	P	Ground	
13	G0	I	Green data	
14	G1	I	Green data	
15	G2	I	Green data	
16	G3	I	Green data	
17	G4	I	Green data	
18	G5	I	Green data	
19	GND	P	Ground	
20	B0	I	Blue data	
21	B1	I	Blue data	
22	B2	I	Blue data	
23	B3	I	Blue data	
24	B4	I	Blue data	
25	B5	I	Blue data	
26	GND	P	Ground	
27	DE	I	Input pin for data enable ; Leave it open in SYNC Mode	
28	VCC	P	Power supply	
29	VCC	P	Power supply	
30	MODE	I	Select DE or SYNC mode. MODE = "Low or Open": DE Mode; MODE = "High": SYNC Mode	

31	DPS	I	DPS = "Low" or "Open" : Normal scan; DPS = "High" : Reverse scan	
32	NC	N	Leave this pin open (for internal use)	
33	NC	N	Leave this pin open (for internal use)	
34	NC	N	Leave this pin open (for internal use)	
35	NC	N	Leave this pin open (for internal use)	
36	NC	N	Leave this pin open (for internal use)	
37	NC	N	Leave this pin open (for internal use)	
38	NC	N	Leave this pin open (for internal use)	
39	NC	N	Leave this pin open (for internal use)	
40	NC	N	No Connection	

Table 3.1.2 Pin Assignment for LCD Interface

Note1: I/O definition: I---Input, O---Output, P---Power/Ground, N---No connection

Note2: All of the GND pins should be connected to the system ground.

Note3: This LCD module supports SYNC& DE mode, the pin setting is different from each other. Please refer to the descriptions.

3.2 CN2 Pin assignment (Back Light)

Connector Information	
LCD Module connector	MS24011P8RA (STM)
Matching connector	P24011P8(STM) /SHR-08V-S(JST)or equivalent

Table 3.2.1 Connector information

No	Symbol	I/O	Description
1	LEDA1	P	LED driving anode (high voltage)
2	LEDK1	P	LED driving cathode (low voltage)
3	LEDA2	P	LED driving anode (high voltage)
4	LEDK2	P	LED driving cathode (low voltage)
5	LEDA3	P	LED driving anode (high voltage)
6	LEDK3	P	LED driving cathode (low voltage)
7	NC	N	No Connection
8	NC	N	No Connection

Table 3.2.2 Pin Assignment for Back Light Interface

Note1: I/O definition: I---Input, O---Output, P---Power/Ground, N---No connection

Note2: All of the GND pins should be connected to the system ground.

4. Absolute Maximum Ratings

Item	Symbol	MIN	MAX	Unit	Remark
Power Voltage	VCC	-0.3	4.0	V	Note1
Input voltage for signals	V _{IN}	-0.3	4.0	V	
Backlight Forward Current	IL	--	55	mA	Per one circuit
Operating Temperature	Top	-30	80	°C	
Storage Temperature	Tst	-35	85	°C	
Relative Humidity Note2	RH	--	≤95	%	Ta≤40°C
		--	≤85	%	40°C < Ta≤50°C
		--	≤55	%	50°C < Ta≤60°C
		--	≤36	%	60°C < Ta≤70°C
		--	≤24	%	70°C < Ta≤80°C
Absolute Humidity	AH	--	≤70	g/m ³	Ta=80°C

Table 4.1 Absolute Maximum Ratings

Note1: Input voltage include all input data.

Note2: Ta means the ambient temperature. It is necessary to limit the relative humidity to the specified temperature range. Condensation on the module is not allowed.

Note3: The absolute maximum rating values of this product are not allowed to be exceeded at any times. A module should be used with any of the absolute maximum ratings exceeded, the characteristics of the module may not be recovered, or in an extreme condition, the module may be permanently destroyed

5. Electrical Characteristics

5.1 DC Characteristics for Panel Driving

Item	Symbol	MIN	TYP	MAX	Unit	Remark	
Supply Voltage	VCC	3.0	3.3	3.6	V		
Supply Current	ICC		45		mA	VCC=3.3V	
Display and function signals	Low Level	VIL	GND	--	0.2×VCC	V	
	High Level	VIH	0.8×VCC	--	VCC	V	
Power Consumption	60Hz	P	--	148.5	--	mW	White pattern

Table 5.1.1 Operating Voltages

5.2 Characteristics for Backlight Driving

Item	Symbol	MIN	TYP	MAX	Unit	Remark
Forward Current	IF	--	50	55	mA	15 LEDs (3 LED Parallel,5 LED Serial)
Forward Current Voltage	VF	13	14.5	16	V	
Backlight Power Consumption	WBL	--	2175	--	mW	
LED life time	--	--	70000	--	Hrs	

Table 5.2.1 LED Backlight Characteristics

Note1: I_F is defined for each channel.

Note2: Optical performance should be evaluated at $T_a=25^\circ\text{C}$ only.

Note3: If LED is driven by high current, high ambient temperature & humidity condition. The life time of LED will be reduced.

Note4: Operating life means brightness goes down to 50% of initial brightness. Typical operating life time is estimated data.

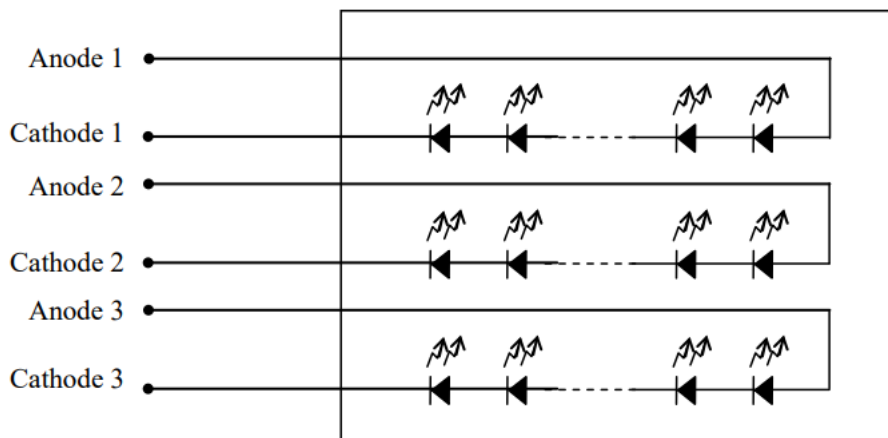

5.3 Power supply voltage ripple

Power supply voltage		MIN	Remark
VCC	3.3 V	≤ 100	mVp-p

Note1: The permissible ripple voltage includes spike noise.

5.4 Fuse

Parameter	Fuse		Rating	Nominal I ² t (A ² s)	Fusing			Remarks
	Type	Supplier			% of current Rating	Clearing time at 25°C		
VCC	F0603H I1000V 032T	AEM	1A/32V	0.08	100%	4 hours min.		Note1
					200%	1 second min.	60 second max.	
					1000%	0.0002seconds min.	0.02seconds max.	

Note1: The power supply's rated current must be more than the fusing current. If it is less than the fusing current, the fuse may not blow in a short time, and then nasty smell, smoke and so on may occur.

5.5 Power ON/OFF Sequence

5.5.1 LCD power on/off

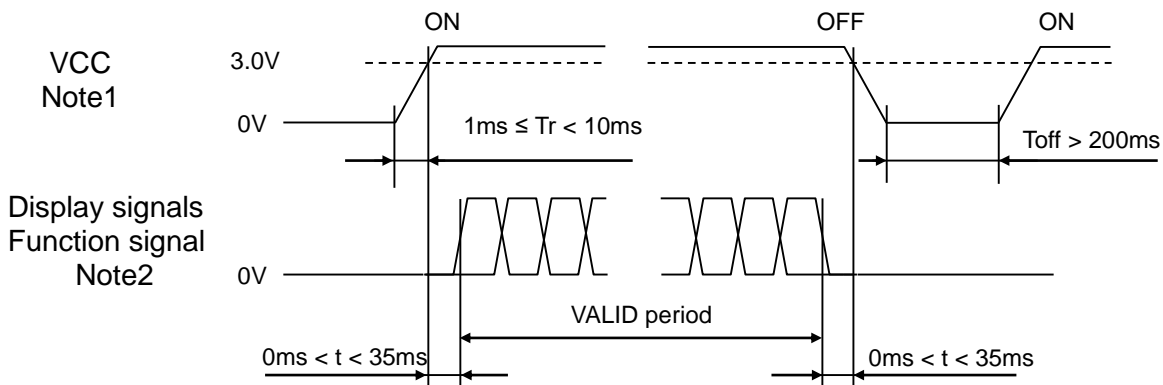

Figure 5.5.1 LCD on/off

Note1: If there is a voltage variation (voltage drop) at the rising edge of VCC below 3.0V in “VCC=3.3V”, there is a possibility that a product does not work due to a protection circuit.

Note2: Display signals (CLK, Hsync, Vsync, DE, DATA (R0 to R5, G0 to G5, B0 to B5)) and function signal (DPS,MODE) must be set to Low or High-impedance, except the VALID period (See above sequence diagram), in order to avoid the circuitry damage.

If some of display and function signals of this product are cut while this product is working, even if the signal input to it once again, it might not work normally. If a customer stops the display and function signals, VCC also must be shut down.

5.5.2 Backlight on/off

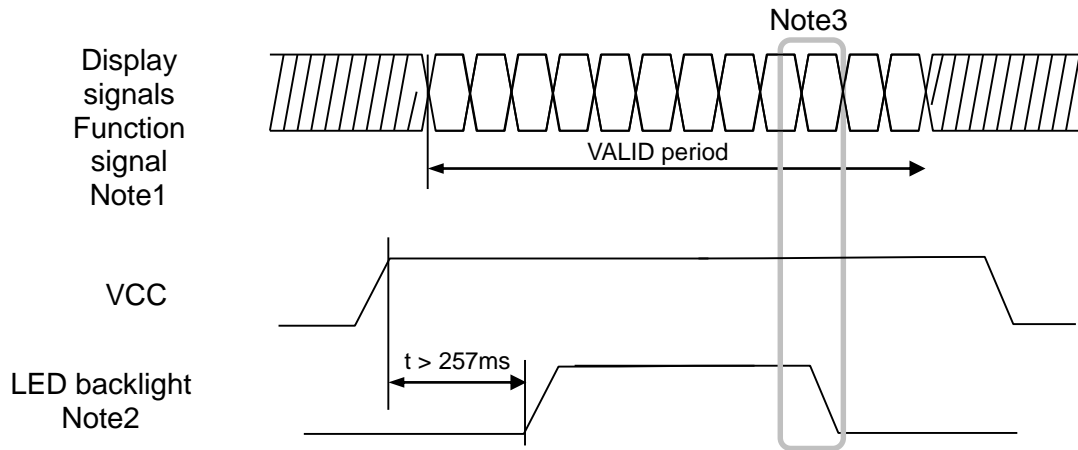

Figure 5.5.2 Backlight on/off

Note1: These are the display and function signals for LCD panel signal processing board.

Note2: The backlight should be turned on after 257ms of the VCC start, in order to avoid unstable data display.

Note3: The backlight should be turned off before 2 frames of the VALID period of display and function signals, in order to avoid unstable data display.

5.6 LCD Module Block Diagram

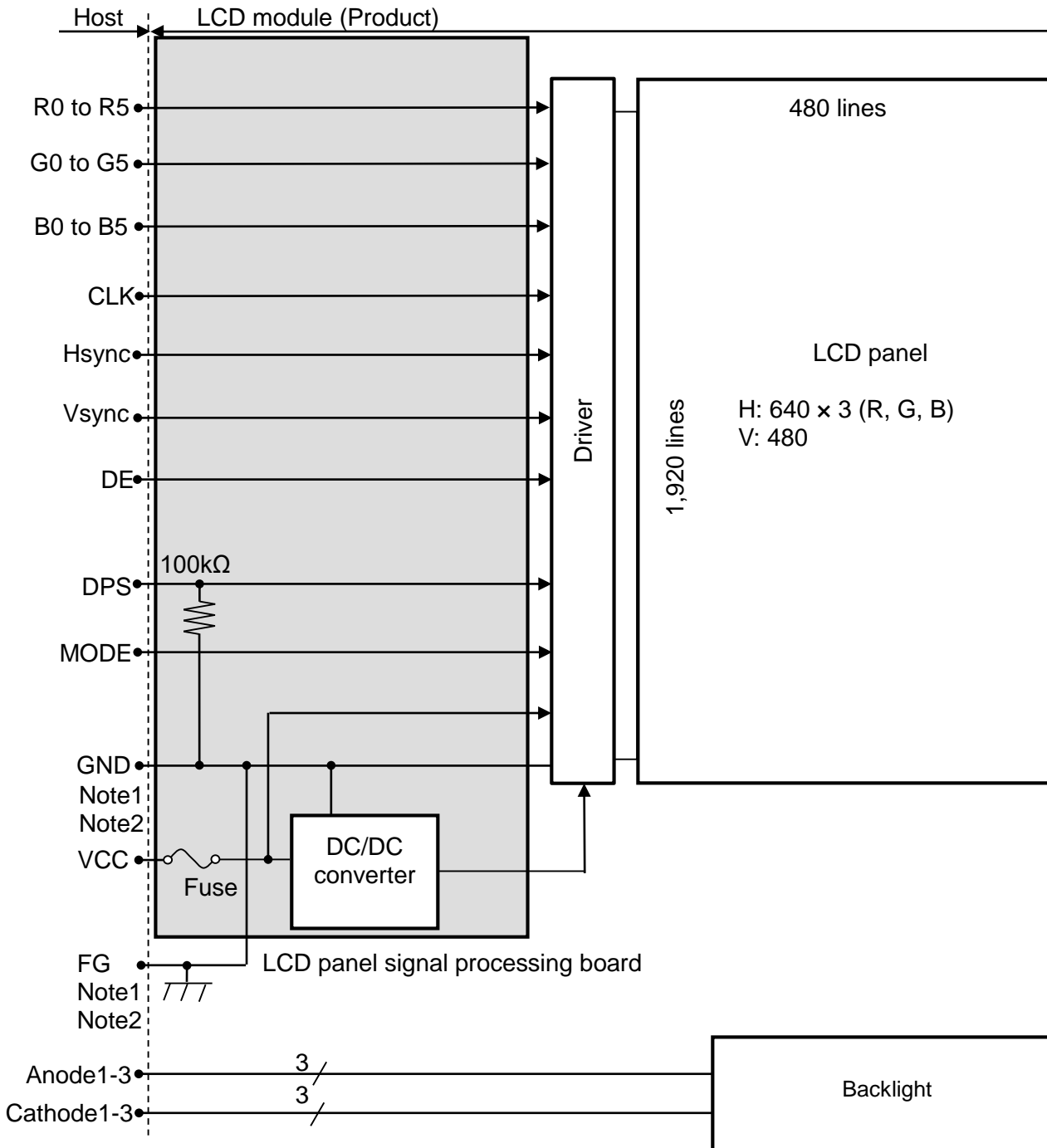

Figure 5.6.1 LCD Module Block Diagram

Note1: Relation between GND (Signal ground) and FG (Frame ground) in the LCD module is as follows.

GND - FG	Connected
----------	-----------

Note2: GND and FG must be connected to customer equipment's ground, and it is recommended that these grounds to be connected together in customer equipment.

5.7 Display Colors And Input Data Signals

This product can display 262,144 colors with 64 gray scales. Also the relation between display colors and input data signals is as the following table.

Display colors		Data signal (0: Low level, 1: High level)																	
		R5	R4	R3	R2	R1	R0	G5	G4	G3	G2	G1	G0	B5	B4	B3	B2	B1	B0
Basic colors	Black	0	0	0	0	0	0	0	0	0	0	0	0	0	0	0	0	0	0
	Blue	0	0	0	0	0	0	0	0	0	0	0	0	1	1	1	1	1	1
	Red	1	1	1	1	1	1	0	0	0	0	0	0	0	0	0	0	0	0
	Magenta	1	1	1	1	1	1	0	0	0	0	0	0	1	1	1	1	1	1
	Green	0	0	0	0	0	0	1	1	1	1	1	1	0	0	0	0	0	0
	Cyan	0	0	0	0	0	0	1	1	1	1	1	1	1	1	1	1	1	1
	Yellow	1	1	1	1	1	1	1	1	1	1	1	1	0	0	0	0	0	0
	White	1	1	1	1	1	1	1	1	1	1	1	1	1	1	1	1	1	1
Red gray scale	Black	0	0	0	0	0	0	0	0	0	0	0	0	0	0	0	0	0	0
	dark	0	0	0	0	1	0	0	0	0	0	0	0	0	0	0	0	0	0
	↑																		
	↓																		
	bright	1	1	1	1	0	1	0	0	0	0	0	0	0	0	0	0	0	0
	Red	1	1	1	1	1	1	0	0	0	0	0	0	0	0	0	0	0	0
Green gray scale	Black	0	0	0	0	0	0	0	0	0	0	0	0	0	0	0	0	0	0
	dark	0	0	0	0	0	0	0	0	0	1	0	0	0	0	0	0	0	0
	↑																		
	↓																		
	bright	0	0	0	0	0	0	1	1	1	1	0	1	0	0	0	0	0	0
	Green	0	0	0	0	0	0	1	1	1	1	1	1	0	0	0	0	0	0
Blue gray scale	Black	0	0	0	0	0	0	0	0	0	0	0	0	0	0	0	0	0	0
	dark	0	0	0	0	0	0	0	0	0	0	0	0	0	0	0	0	1	0
	↑																		
	↓																		
	bright	0	0	0	0	0	0	0	0	0	0	0	0	1	1	1	1	0	1
	Blue	0	0	0	0	0	0	0	0	0	0	0	0	1	1	1	1	1	1

Table 5.7.1 Display Colors And Input Data Signals

5.8 Display Positions

The following table is the coordinates per pixel

C (0, 0)													
<table border="1" style="margin: auto;"> <tr> <td style="padding: 2px 10px;">R</td> <td style="padding: 2px 10px;">G</td> <td style="padding: 2px 10px;">B</td> <td colspan="4"></td> </tr> </table>							R	G	B				
R	G	B											
C(0, 0)	C(1, 0)	...	C(X, 0)	...	C(638, 0)	C(639, 0)							
C(0, 1)	C(1, 1)	...	C(X, 1)	...	C(638, 1)	C(639, 1)							
⋮	⋮	⋮	⋮	⋮	⋮	⋮							
C(0, Y)	C(1, Y)	...	C(X, Y)	...	C(638, Y)	C(639, Y)							
⋮	⋮	⋮	⋮	⋮	⋮	⋮							
C(0, 478)	C(1,478)	...	C(X,478)	...	C(638,478)	C(639,478)							
C(0,479)	C(1,479)	...	C(X,479)	...	C(638,479)	C(639,479)							

Table 5.8.1 Display Positions

The following figures are seen from a front view. Also the arrow shows the direction of scan.

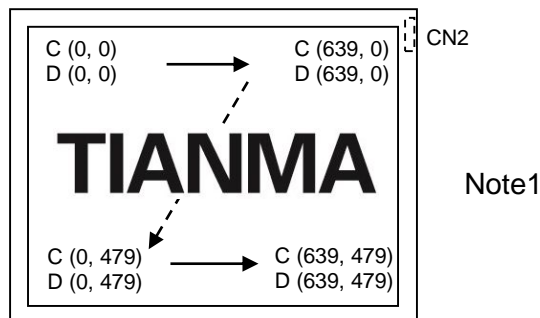

Figure1. DPS= Low or Open (Normal scan)

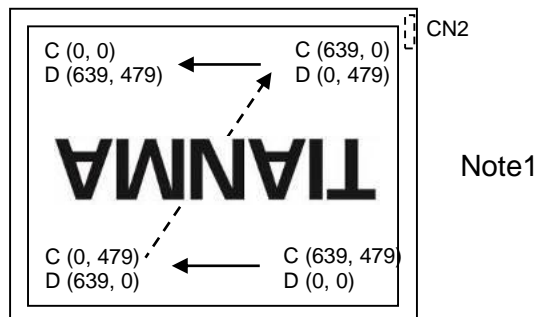

Figure2. DPS= High (Reverse scan)

Note1: Meaning of C (X, Y) and D (X, Y)

C (X, Y): The coordinates of the display position

D (X, Y): The data number of input signal for LCD panel signal processing board

6. Timing Characteristics

6.1 AC characteristics

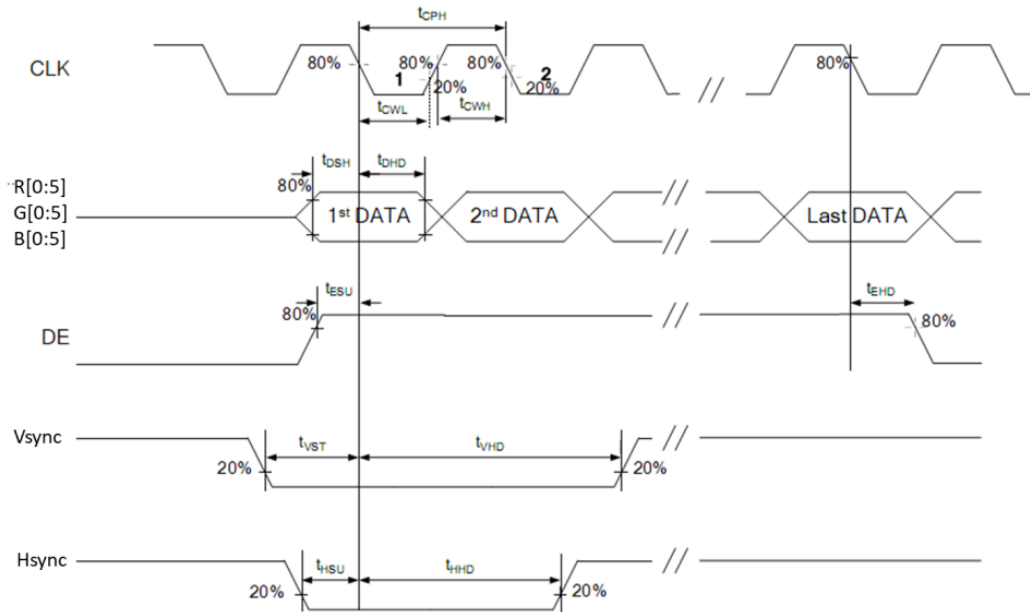

Figure 6.1.1 Input Timing Chart

Item	Signal	Symbol	Condition	Rating		Unit
				Min.	Max.	
CLK cycle time		t_{CPH}		34.5	47.6	ns
CLK pulse high duty	CLK	t_{CWH}		40	60	%
CLK pulse low duty		t_{CWL}		40	60	
Vsync setup time	Vsync	t_{VST}		4	-	ns
Vsync hold time		t_{VHD}		2	-	
Hsync setup time	Hsync	t_{HSU}		4	-	
Hsync hold time		t_{HHD}		2	-	
Data setup time	R[0:5] G[0:5] B[0:5]	t_{DSH}		4	-	
Data hold time		t_{DHD}		2	-	
DE setup time	DE	t_{ESU}		4	-	
DE hold time		t_{EHD}		2	-	

Table 6.1.1 Input Timing Chart

6.2 Data Input Timing Parameter Setting

6.2.1 SYNC MODE

Parameter		Symbol	min	typ	max	Unit	Remarks
CLK	Frequency	1/tc	21	25.2	29	MHz	Note1
Hsync	Cycle	t _H	816			CLK	
	Display period	t _{HD}	640			CLK	
	Front-porch	t _{HFP}	32			CLK	
	Pulse width	t _{HPW}	10	10	96	CLK	
	Back-porch	t _{HBP}	144			CLK	Note2
Vsync	Cycle	t _V	525			H	Note3
	Display period	t _{VD}	480			H	
	Front-porch	t _{VFP}	12			H	
	Pulse width	t _{VPW}	2	3	5	H	
	Back-porch	t _{VBP}	33			H	Note2

Table 6.2.1 Input Timing Parameters on Fixed Mode

Note1: Definition of parameters is as follows.

$$t_c = 1\text{CLK}, t_H = 1\text{H}$$

Note2: The data of Back-porch includes Pulse width.

Note3: Frame rate = $1/t_c/t_H/t_V$.

6.2.2 DE MODE

Parameter		Symbol	min.	typ.	max.	Unit	Remarks	
CLK	Frequency	1/tc	21	25.2	29	MHz	Note1	
DE	Horizontal	Cycle	t _H	744	800	840		CLK
		Display period	t _{HD}	640			CLK	Note2
	Vertical (One frame)	Cycle	t _V	517	525	537	H	Note3
		Display period	t _{VD}	480			H	

Table 6.2.2 Input Timing Parameters on DE Mode

Note1: Definition of parameters is as follows.

$$t_c = 1\text{CLK}, t_H = 1\text{H}$$

Note2: Hsync signal (Pin No.3 of CN1) and Vsync signal (Pin No.4 of CN1) are not used inside the product at DE mode; please tie H or L in DE mode.

Note3: Vertical cycle (t_V) should be specified in integral multiple of Horizontal cycle (t_H).

Note4: Frame rate = $1/t_c/t_H/t_V$.

6.3 SYNC Mode Timing Diagram

Parallel RGB

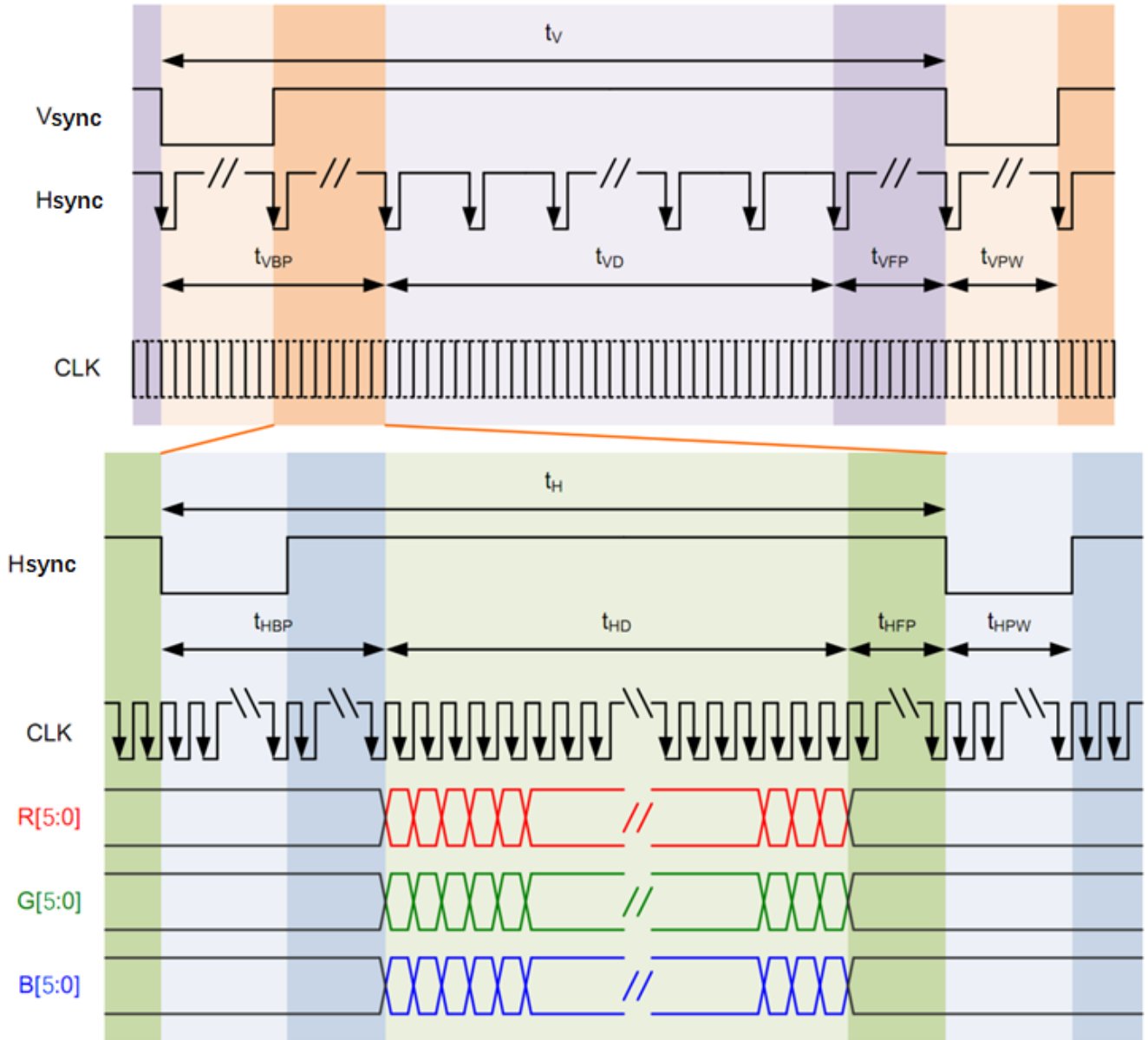

Figure 6.3.1 Data Input Timing Diagram Under SYNC Mode

6.4 DE Mode Timing Diagram

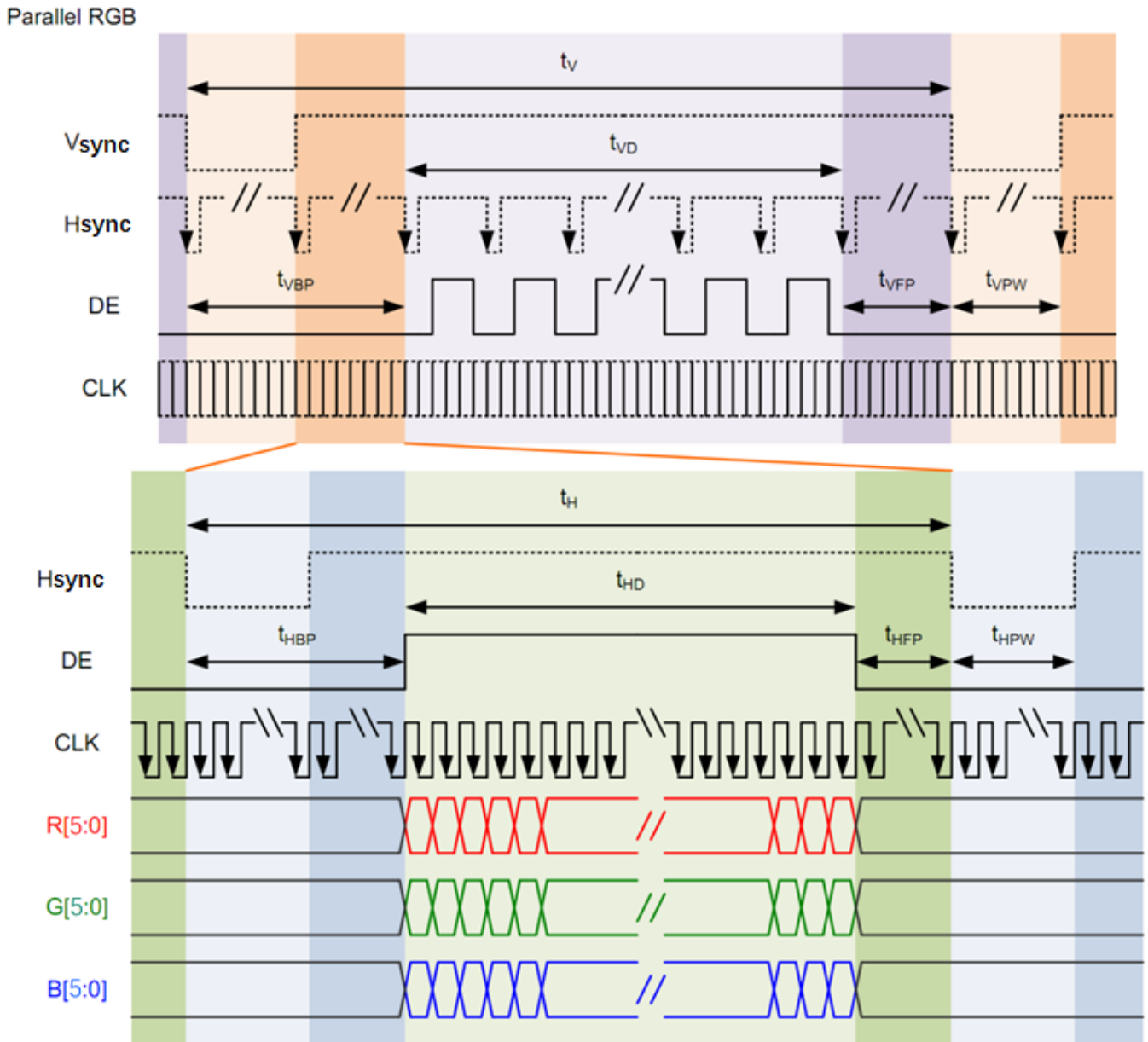

Figure 6.4.1 Data Input Timing Diagram Under DE Mode

7. Optical Characteristics

Item	Symbol	Condition	Min	Typ	Max	Unit	Remark
View Angles	θT	$CR \cong 10$	70	88		degree	Note2,3
	θB		70	88			
	θL		70	88			
	θR		70	88			
Contrast Ratio	CR	$\theta=0^\circ$	1000	1300			Note 3
Response Time	T_{ON}	25°C		30	40	ms	Note 4
	T_{OFF}						
Chromaticity	White	x	0.262	0.312	0.362		Note 1,5
		y	0.290	0.340	0.390		
	Red	x	0.524	0.574	0.624		Note 1,5
		y	0.285	0.335	0.385		
	Green	x	0.289	0.339	0.389		Note 1,5
		y	0.544	0.594	0.644		
	Blue	x	0.104	0.154	0.204		Note 1,5
		y	0.059	0.109	0.159		
Uniformity	U		75	80		%	Note 6
NTSC	-		45	50		%	Note 5
Luminance	L		350	500		cd/m ²	Note 7

Table 7.1 Optical Parameters

Test Conditions:

1. $I_F=50$ mA, and the ambient temperature is 25°C.
2. The test systems refer to Note1 and Note2.

Note1: Definition of optical measurement system.

The optical characteristics should be measured in dark room. After 5 Minutes operation, the optical characteristics are measured at the center point of the LCD screen.

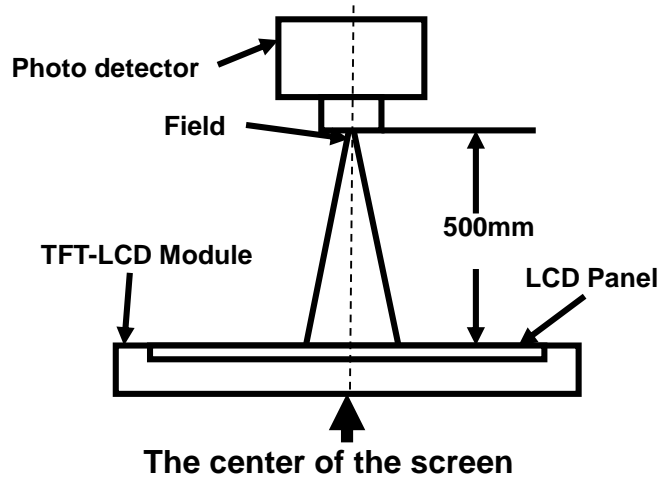

Fig1. Measurement Set Up

Note2: Definition of viewing angle range and measurement system. Viewing angle is measured at the center point of the LCD .

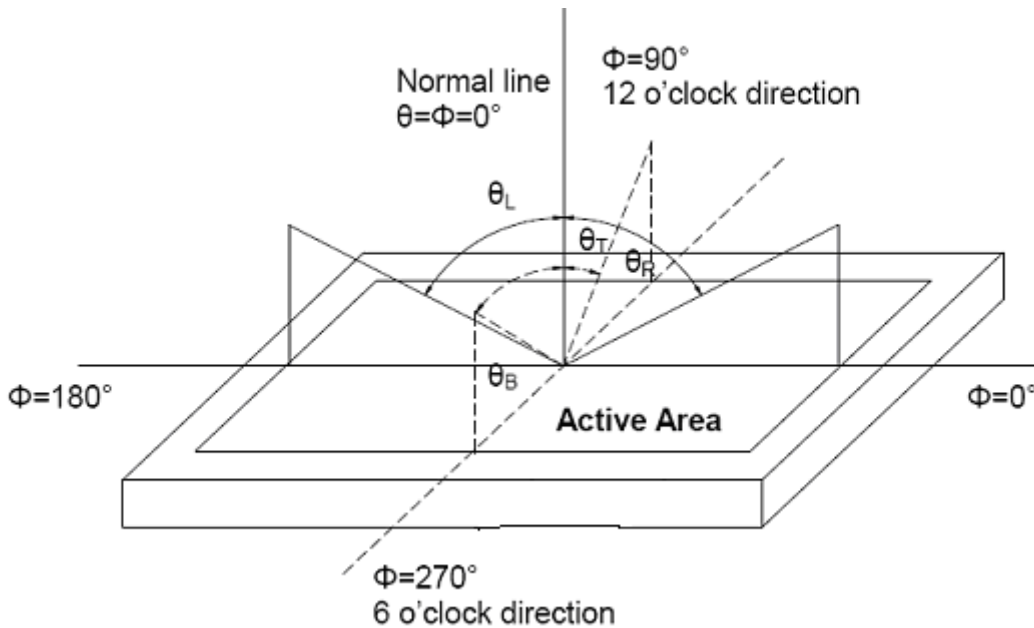

Fig2. Measurement viewing angle

Note3: Definition of contrast ratio

$$\text{Contrast ratio (CR)} = \frac{\text{Luminance measured when LCD is on the "White" state}}{\text{Luminance measured when LCD is on the "Black" state}}$$

Note4: Definition of Response time

For SFT LCM, the response time is defined as the LCD optical switching time interval between “White” state and “Black” state. Rise time (T_r) is the time between photo detector output intensity changed from 10% to 90%. And fall time (T_f) is the time between photo detector output intensity changed from 90% to 10%.

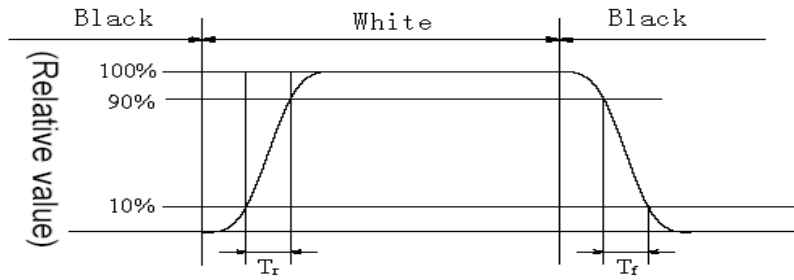

Fig3. Response Time Testing(SFT)

Note5: Definition of color chromaticity (CIE1931)

Color coordinates measured at center point of LCD.

Note6: Definition of Luminance Uniformity

Active area is divided into 9 measuring areas (Refer Fig.4). Every measuring point is placed at the center of each measuring area.

$$\text{Luminance Uniformity (U)} = \text{Lmin} / \text{Lmax}$$

Lmax: The measured Maximum luminance of all measurement position.

Lmin: The measured Minimum luminance of all measurement position.

L-----Active area length; W----- Active area width

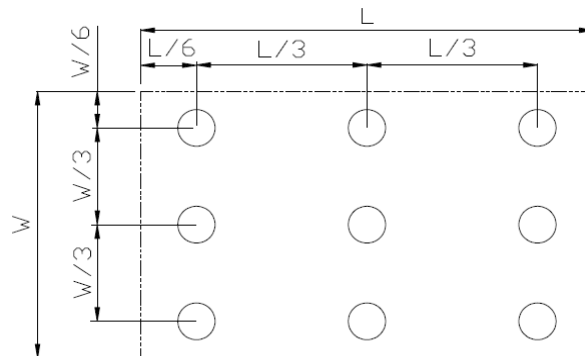

Fig4. Luminance Uniformity Measurement Locations(9 points)

Note7: Definition of Luminance:

Measure the luminance of white state at center point.

8. Reliability Test

No	Test Item	Condition	Remarks
1	High Temperature Operation	Ta = +80°C, 240 hours	IEC60068-2-1:2007 GB2423.2-2008
2	Low Temperature Operation	Ta= -30°C, 240 hours	IEC60068-2-1:2007 GB2423.2-2008
3	High Temperature Storage	Ta = +85°C, 240 hours	IEC60068-2-1:2007 GB2423.2-2008
4	Low Temperature Storage	Ta = -35°C, 240 hours	IEC60068-2-1:2007 GB2423.2-2008
5	High Temperature and Humidity(operation)	Ta = 60±2°C, 90% RH,240hours Display data is white	IEC60068-2-78 GB/T2423.3
6	Heat Cycle (operation)	-30±3°C,1 hour 80±3°C,1 hour 50cycles,4 hours/cycle Display data is white	Start with cold temperature, End with high temperature, IEC60068-2-14:1984,GB2423.22-2002
7	Thermal Shock (non-operation)	-30±3°C,30minutes 80±3°C,30minutes 100cycles,1hours/cycle temperature transition time is within 5 minutes	Start with cold temperature, End with high temperature, IEC60068-2-14:1984,GB2423.22-2002
8	ESD	150PF, 330Ω 9point, 25 times each place Air : ±15KV Contact : ±8KV	IEC61000-4-2:2001 GB/T17626.2-2006
9	Vibration (Non-operation)	5~100Hz 19.6m/s ² 1 minute/cycle X, Y, Z 120 times each direction	IEC60068-2-6 GB/T17626.6
10	Mechanical shock (Non-operation)	539m/s ² ,11 ms ±X, ±Y, ±Z 5 times each direction	IEC60068-2-27 GB/T2423.5

Table 8.1 RA test condition

Note1: Temperature is the ambient temperature of sample

Note2: Before cosmetic and function test, the product must have enough recovery time, at least 2 hours at room temperature.

Note3: In the standard condition, there shall be no practical problem that may affect the display function. After the reliability test, the product's function only be guaranteed, but not for all of the cosmetic specification.

9. Mechanical Drawing

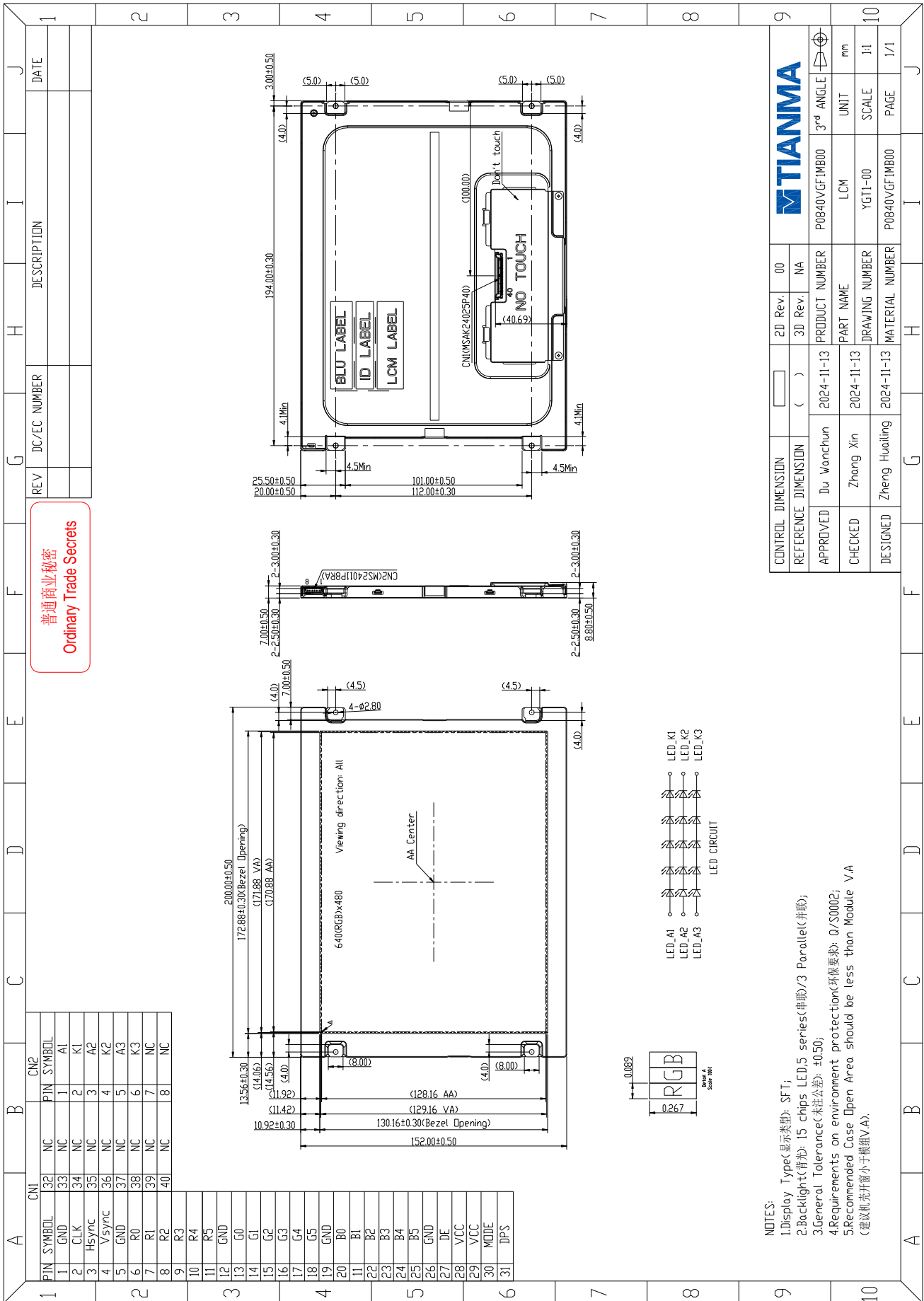

NOTES:
 1.Display Type(显示类型): SF T;
 2.Backlight(背光): 15 chips LED,S series(串联)/3 Parallel(并联);
 3.General Tolerance(未注公差): ±0.50;
 4.Requirements on environment protection(环保要求): 0/S0002;
 5.Recommended Case Open Area should be less than Module V/A
 (建议开孔开槽小于模组V/A).

10. Packing Instruction

No	Item	Model (Material)	Dimensions(mm)	Unit Weight(Kg)	Quantity	Remark	
1	LCM module	P0840VGF1MB00	200.0×152.0×8.8	0.233	10		
2	Partition board	Corrugated paper	202×193×5	0.02	4		
3	Partition board	Corrugated paper	504×346×5	0.086	1		
4	Anti-static Bag	LD-PE	360×255	0.008	10		
5	EPP1	EPP	505×345×140	0.13	1		
6	EPP2	EPP	345×40×40	0.009	2		
7	Carton	Corrugated paper	508×350×237	0.973	1		
8	Label	PE	100×52	0.001	1		
9	Total weight	3.698±5 % kg					

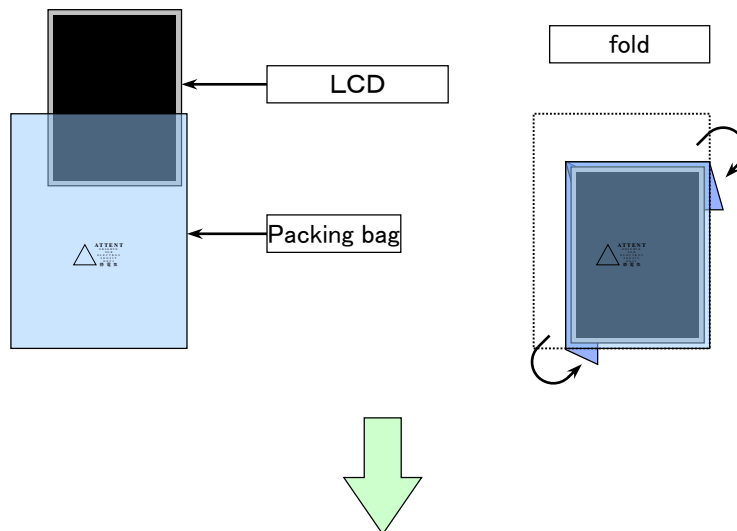

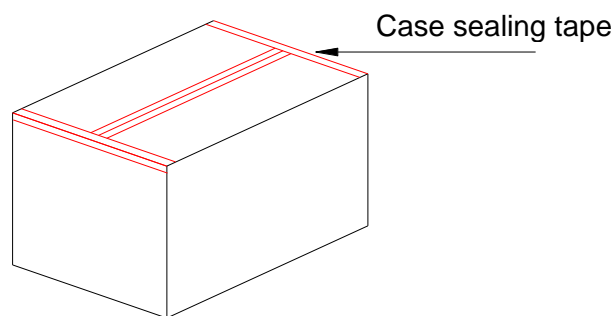
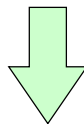
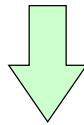
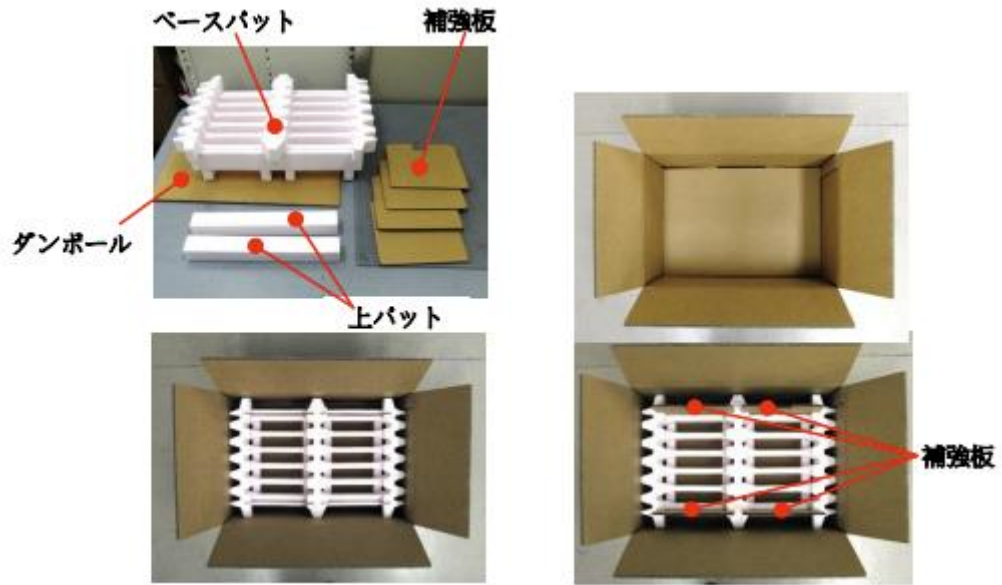

11. Precautions for Use of LCD Modules

11.1 Handling Precautions

- (1) The display panel is made of glass. Do not subject it to mechanical shock by dropping it, etc.
- (2) If the display panel is damaged and the liquid crystal fluid inside it leaks out be sure not to get any in your mouth. If the fluid comes into contact with your skin or clothes promptly wash it off using soap and water.
- (3) Do not apply excessive force to the display surface or the bezel since this may cause the color tone to vary.
- (4) The polarizer covering the display surface of the LCD module is soft and easily scratched. Handle the polarizer carefully.
- (5) If the display surface is contaminated, breathe on the surface and gently wipe it with a soft dry cloth. If it is still not completely clear use a moist cloth with one of the following solvents:
 - Isopropyl alcohol
 - Ethyl alcoholSolvents other than those mentioned above may damage the polarizer. Specifically, do not use the following:
 - Water
 - Ketone
 - Aromatic solvents
- (6) Do not disassemble the LCD Module.
- (7) If powered off, do not apply the input signals.
- (8) To prevent destruction of the module by static electricity, be careful to maintain an optimum work environment.
- (9) Be sure to ground your body when handling the LCD Modules.
- (10) Tools used for assembly, must be properly grounded.
- (11) To reduce the amount of static electricity generated, do not conduct assembly or other work under very low humidity conditions.
- (12) The LCD Module is covered with a film to protect the display surface, remove film slowly under the ionizer.

11.2 Storage precautions

- (1) When storing the LCD modules avoid exposure to direct sunlight or to the light of fluorescent lamps.
- (2) The LCD modules should be stored within the rated storage temperature range. The recommend condition is: Temperature: 0 ~ 35 °C at normal humidity.
- (3) The LCD modules should be stored in a room without acid, alkali or other harmful gas.

11.3 Transportation Precautions

The LCD modules should not be dropped or subject to violent mechanical shock during transportation. Also they should avoid excessive pressure, water, high humidity and direct sunlight.

11.4 Screen saver Precautions

Not display the fixed pattern for a long time. Use a screen saver, if the fixed pattern is displayed on the screen

11.5 Safety Precautions

- (1) When you waste damaged or unnecessary LCDs, it is recommended to crush LCDs into pieces and wash them off with solvents such as acetone and ethanol, which should later be burned
- (2) Be sure to turn off the power supply when inserting or disconnecting the LED backlight cable.
- (3) LED driver should be designed to limit or stop its function when over current is detected on the LED.